

102  
EXTRAORDINARY WAYS OF USING DUPLEX DIODES

# RADIO

REG. U.S. PAT. OFF.

# WORLD

The First National Radio Weekly — 643d Issue, 13th Year

Automatic Antenna  
Series Condenser for  
Short Waves

Diodes in T-R-F Circuits

Battery-Operated Super

## 40 Mfd. and 45 Henries in B Filter

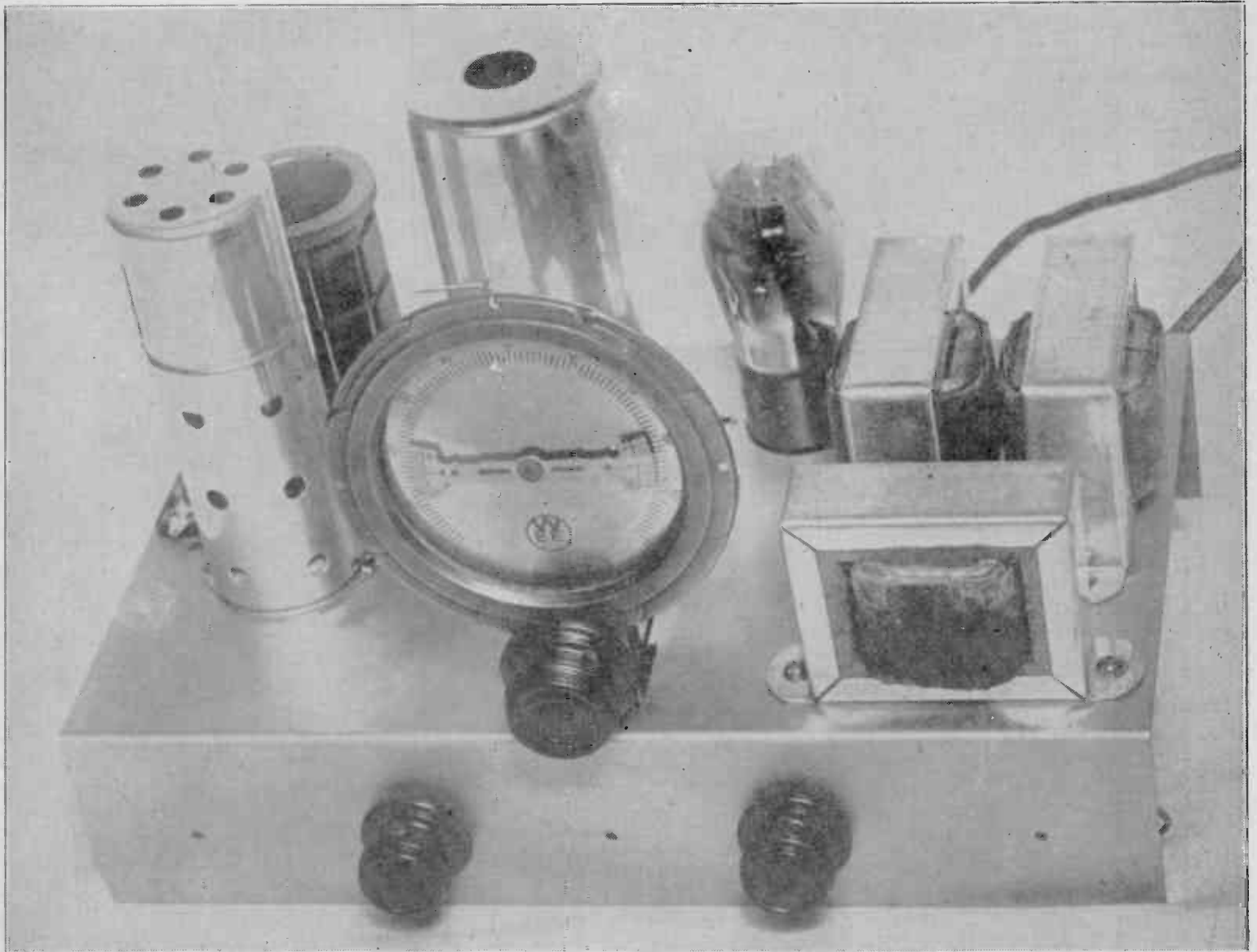

This 3-tube "Universal" type set for short waves has a husky B filter. See pages 8 and 9.

JULY  
21  
1934

RESONANCE  
EXPLAINED



HUM ELIMINATED  
FROM SHORT WAVES

15¢  
Per Copy

**SHORT WAVE—RADIO EQUIPMENT—SERVICE LEADERS**



**Postal DeLuxe S.W. Converter**  
Fully described June 30, Radio World; June 2, N. Y. Sun; Radio News, S. W. Radio, S. W. Craft, and Radio Craft. Send for Free Booklet.  
135 W. Liberty St. New York, N. Y.

**Short-Wave and Public Address Specialists**  
Every short-wave receiver or public address system imaginable on display at our new offices in the GREEN EXCHANGE BUILDING.  
You are cordially invited to visit us.  
**PROMPT RADIO SERVICE CO.**  
130 Cedar Street New York, N. Y.

**Brush Up on Short Waves**  
ORDER a copy of "The Short-Wave Authority," by J. E. Anderson and Herman Bernard, so you can read the complete exposition of this absorbing topic, and have a ready reference book that solves your short-wave problems. Constructional circuits included. Special chapter on Treasure-Seeking Devices. Great details on superheterodynes and padding. Send no money. Just order book sent C.O.D. at \$3.00.  
Reliable Radio Co. 145 W. 45th St., N. Y. C.

**Ham & Servicemen's Headquarters**  
We carry a complete line of Public Address, Short Wave and Transmitting parts in stock. Largest assortment of Dynamic and Magnetic Speakers in the country.  
**TRY-MO RADIO CO., N. Y. CITY**  
85 Cortlandt St. — 179 Greenwich St.

*Now, a high-powered*  
**RADIO ENGINEERING LIBRARY**  
*—especially selected by radio specialists of McGraw-Hill publications*  
*—to give most complete, dependable coverage of facts needed by all whose fields are grounded on radio fundamentals*  
*—available at a special price and terms.*



**5 VOLUMES, 2981 PAGES, 2000 ILLUSTRATIONS**

1. Everitt's COMMUNICATION ENGINEERING
2. Terman's RADIO ENGINEERING
3. Chaffee's THEORY OF THERMIONIC VACUUM TUBES
4. Hund's HIGH-FREQUENCY MEASUREMENTS
5. Henney's RADIO ENGINEERING HAND BOOK

These books cover circuit phenomena, tube theory, networks, measurements, and other subjects—give specialized treatment of all fields of practical design and application. They are books of recognized position in the literature—books you will refer to and be referred to often. If you are a practical designer, researcher or engineer in any field based on radio, you want these books for the help they give in hundreds of problems throughout the whole field of radio engineering.

10 days' examination. Special price. Monthly payments. \$20.00 worth of books cost you only \$23.50 under this offer. Add these standard works to your library now; pay small monthly installments, while you use the books.

**SEND THIS ON-APPROVAL COUPON**  
McGraw-Hill Book Co., Inc.  
330 W. 42nd St., New York, N. Y.

Send me Radio Engineering Library, 5 vols., for 10 days' examination on approval. In 10 days I will send \$2.50, plus few cents postage, and \$3.00 monthly till \$23.50 is paid, or return books postpaid. (We pay postage on orders accompanied by remittance of first installment.)

Name.....  
Address.....  
City and State.....  
Position.....  
Company..... RW-7-21-34

**Wind Your Own Short-Wave Coils**

Using data published in May 19th issue of Radio World.

1 1/2-inch diameter ribbed Bruno forms, bakelite moulded, set of four, vari-colored, four-pin bases.....\$1.10  
Same as above, but six-pin base (four forms).....\$1.20  
Set of four Bruno two-winding, vari-colored forms.....\$2.50  
Set of four Brunos, three-winding.....\$3.00  
Insuline two-winding coils (four).....\$2.00  
Insuline three-winding coils (four).....\$2.40

**SCREEN GRID COIL CO.**  
145 West 45th Street New York, N. Y.

**115 DIAGRAMS FREE**

115 Circuit Diagrams of Commercial Receivers and power supplies supplementing the diagrams in John F. Eider's "Trouble Shooter's Manual." These schematic diagrams of factory-made receivers, giving the manufacturer's name and model number on each diagram, include the MOST IMPORTANT SCREEN GRID RECEIVERS.

The 115 diagrams, each in black and white, on sheets 4 1/4 x 11 inches, punched with three standard holes for loose-leaf binding, constitute a supplement that must be obtained by all possessors of "Trouble Shooter's Manual," to make the manual complete.

Circuits include Bosch 64 D. C. screen grid; Balkite Model F. Crosley 50, 51, 52 screen grid; Eready series 18 screen grid; Rria 324 A.C. screen grid; Peerless Electrostatic series; Philco 76 screen grid.

Subscribe for Radio World for 3 months at the regular subscription rate of \$1.50, and have these diagrams delivered to you FREE!

Radio World, 145 West 45th St., New York, N. Y.

**They Work!**  
**FILTER CONDENSERS**

Here is a dry electrolytic self-healing condenser of 8 mfd. capacity which will give long, hum-free service in power supplies. The condenser is intended for use with an operating voltage of 400 volts, or slightly over, but will withstand a peak voltage of 600.

Type D Condenser, 49c  
**RELIABLE RADIO CO.**  
143 West 45th St. New York, N. Y.

**NEW EDITION (1934)**  
**"THE RADIO AMATEUR'S HANDBOOK"**

published by the American Radio Relay League, just out (eleventh edition). Almost completely rewritten and re-illustrated. Changes in technique introduced during 1933 fully covered. Several chapters entirely new.

PRICE, \$1.00, POSTPAID  
**RADIO WORLD, 145 West 45th Street, New York, N. Y.**

**RADIO WORLD AND RADIO NEWS.** Both for one year, \$7.00. Foreign \$8.50. Radio World, 145 W. 45th St., N. Y. City.

**NEW STATION FINDER**  
**HAS AUTOMATIC ELECTRIC HARMONIC COUNTER**

To Herman Bernard are due the Short-Wave Converter (1923), the first commercial Signal Generator with direct frequency-ready dial (1931), high accuracy in low-priced Signal Generators (1932) and frequency stability close to that of a crystal, without extra cost (1933).

Now he announces for the first time his newest invention, the Automatic Electric Harmonic Counter, incorporated in his new All-Wave Station Finder, Model SF-1.

The purpose of the Station-Finder is to enable determination of the frequency or wavelength of a station being heard, without waiting for call letters; for tuning a receiver to a desired frequency, to be ready to bring in a particular station; to ascertain if the station desired to be heard is on the air, and, if so, whether the receiver is sensitive enough to bring in the station then; and to line up broadcast and short-wave channels, 500 kc to 60 mc, thus being useful also to service men for calibrating receivers, and as an adjunct to their low-frequency (intermediate) Signal Generators.

The use of harmonics always has been attended with possibilities of confusion, with consequent risk of large errors. What was needed was some system of identifying the harmonics. The Bernard method has the effect of constituting his Station-Finder a combination multiplying, subtracting and dividing machine, where these functions are used for making the Station-Finder "conscious" of the harmonic used. This enables the manufactured calibration of a scale from 1 to 60 mc, with frequencies read directly, so the user does not concern himself with which harmonic is which.

The Bernard method is entirely electrical and uses no moving adjuncts. With this method no switching is necessary.

The fundamental frequencies of the Station-Finder are 500 to 1,000 kc, in 5 kc steps, all direct-reading. The Station-Finder also is direct-reading in wavelengths, 300 to 600 meters, in steps of 5 and 10 meters. Moreover, the 1 to 60 mc range can be determined in wavelengths, and the Station-Finder thus is also a converter of wavelengths to frequencies or frequencies to wavelengths, 60 mc to 500 kc, 5 meters to 600 meters, and will give answers in frequencies or wavelengths.

Model SF-1 works on a.c. (any frequency) and on d.c., 90-120 volts, has a frequency stability of one part in 25,000, an accuracy of 1 per cent. on fundamentals, with practicality of extending this accuracy to many high frequencies, zero beats at all settings, is contained in a black wrinkle-finish shield cabinet, and comes equipped with 76 tube, all ready for use. Order Cat. SF-1 (shipping weight, 4 lbs.).

List Price, \$11.00 Net Price, \$6.60

**RELIABLE RADIO COMPANY, 145 West 45th Street, New York, N. Y.**



**Quick-Action Classified Advertisements**  
7c a Word—\$1.00 Minimum

**LIFE TIME OPPORTUNITY.** Practical money-making schemes, Legitimate, Local, Mail, travel, city, town. Ten cents coin. Bristol Mailing Service, Box 51, Taunton, Mass.

**INVENTIONS WANTED, PATENTED, UNPATENTED,** any size, any material, for any legitimate purpose. Bosley Mfg. Co., 79 High St., Torrington, Conn.

**AGENTS: HUNDREDS OF FAST SELLERS:** blades and soaps for men; also household articles. La France Products, 34 Merchants Row, Boston, Mass.

**"INVENTIONS, PATENTS AND TRADE-MARKS,"** by Milton Wright, Attorney and Counselor-at-Law. How to make your inventions pay—how to secure the utmost in legal protection. Second Edition, 310 pages. Price, \$2.50. **RADIO WORLD, 143 West 45th St., New York City.**

**RADIO WORLD AND POPULAR MECHANICS MAGAZINE**—Radio World is \$6.00 a year, and Popular Mechanics Magazine is \$2.50 a year. Popular Mechanics Magazine does not cut rates, but Radio World will send both publications for one year for \$7.00. **RADIO WORLD, 145 West 45th St., New York City.**

**"THE RADIO HANDBOOK,"** including Television and Sound Motion Pictures. By James A. Moyer and John F. Westrel, both of the Massachusetts Department of Education. For engineers, designers, operators, service men, experimenters. 886 pages, 650 illustrations, flexible. Price, \$5.00. **RADIO WORLD, 143 West 45th St., New York City.**

**HENLEY'S "TWENTIETH CENTURY BOOK OF RECIPES, FORMULAS & PROCESSES."** New 1933 Edition. Ten thousand processes, recipes, trade secrets and money-making formulas. For the laboratory, workshop, factory and home. Some subjects fully covered: Dyes, Inks, Waterproofing, Perfumes, Cement, Plating, Glass, Dentifrices, Varnishes, Soaps, Glues, Paints, Adhesives, Emulsifying, Hairdressings, Cosmetics, Oils. Price, \$4.00. Book Dept., Radio World, 145 W. 45th St.,

ROLAND BURKE HENNESSY  
*Editor*

HERMAN BERNARD  
*Managing Editor*

# RADIO WORLD

REG. U. S. PAT. OFF.

*The First National Radio Weekly*  
THIRTEENTH YEAR

J. E. ANDERSON  
*Technical Editor*

J. MURRAY BARRON  
*Advertising Manager*

Vol. XXV

JULY 21st, 1934

No. 19. Whole No. 643

*Published Weekly by Hennessy Radio Publications Corporation, 145 West 45th Street, New York, N. Y.*

Editorial and Executive Offices: 145 West 45th Street, New York

Telephone: BR-yant 9-0558

OFFICERS: Roland Burke  
Hennessy, *President* and  
*Treasurer.*  
M. B. Hennessy, *Vice-*  
*President.*  
Herman Bernard, *Secre-*  
*tary.*

Entered as second-class matter March, 1922, at the Post Office at New York, N. Y., under Act of March 3, 1879. Title registered in U. S. Patent Office. Printed in the United States of America. We do not assume any responsibility for unsolicited manuscripts, photographs, drawings, etc., although we are careful with them.

Price, 15c per Copy; \$6.00  
per Year by mail. \$1.00 extra  
per year in foreign countries.  
Subscribers' change of ad-  
dress becomes effective two  
weeks after receipt of notice.

## Automatic Condenser In Series with Antenna Is Worked Simultaneously with Coil Switch

*By Herman Bernard*

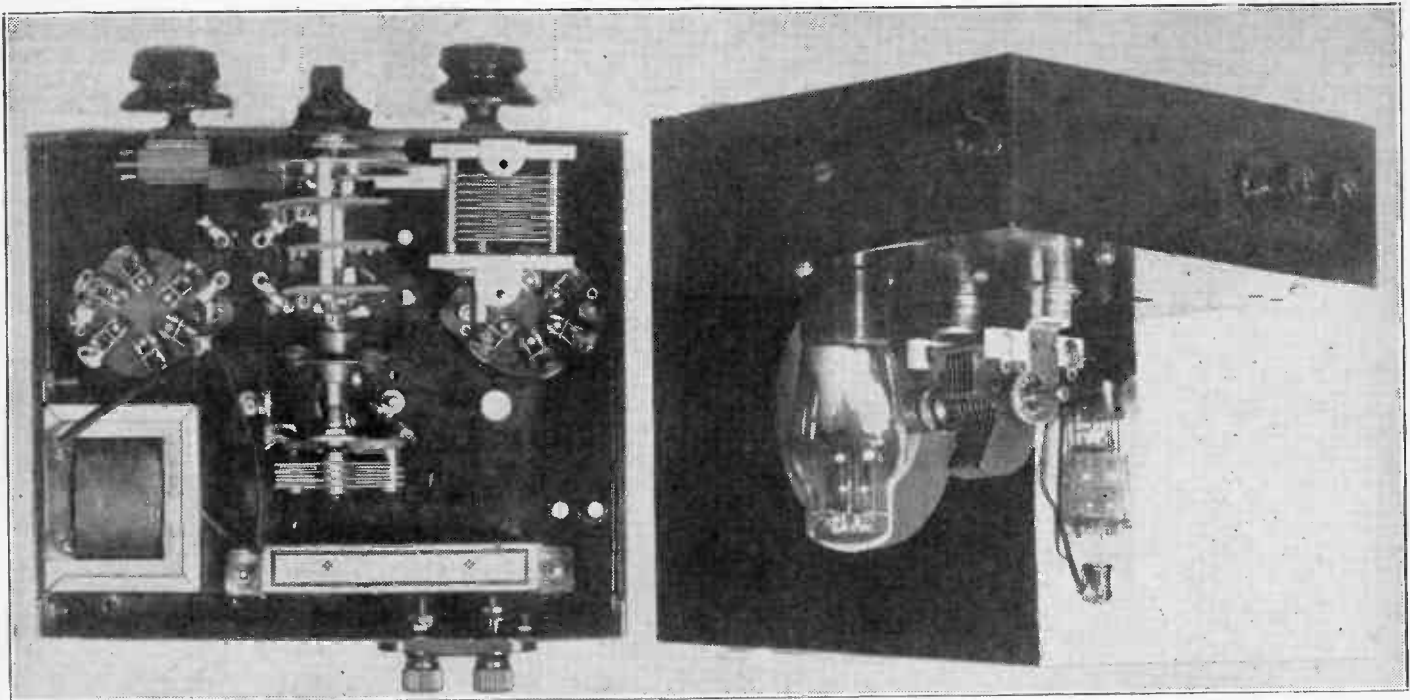

Seen from the rear, the detector tube is at left and the rectifier at right. The tuning condenser is elevated to the proper height for the dial by washers through which the holding screw is passed into the condenser frame bracket.

The method of combining the operation of the switch with variation of the series antenna condenser. The switch shaft protrudes at rear, where a flexible coupling of insulated type is mechanically joined to the series condenser shaft.

SOME of the refinements of the larger receivers may be introduced into the smaller ones, although this process of improving the convenience and usefulness of the more modest receivers has been slow. The advantage of some sort of frequency calibration, even if not of a precision sort, should be included, and besides a station-finder may be used either as an auxiliary, or as a built-in product, for more accurate determination of frequencies. The reason is that in an oscillator, such as the station-finder would be, there is a simple one-tube

circuit where the constants can be held much more nearly permanent than in a receiver that has a multiplicity of tuned circuits and numerous adjuncts subject to variations that affect frequency. In other words, the receiver will work away from a calibration much more than the station-finder would, for it is easy to maintain an accuracy of 1 per cent. for the station-finder.

Besides the frequency-calibration advantage, there is no  
*(Continued on next page)*

The short-wave receiver, using coil-switching, also has the equivalent of a fixed capacity of different value as series antenna condenser for each switch-point setting. This facilitates adherence to any calibration and leaves the throttle condenser setting as principal calibration variant.

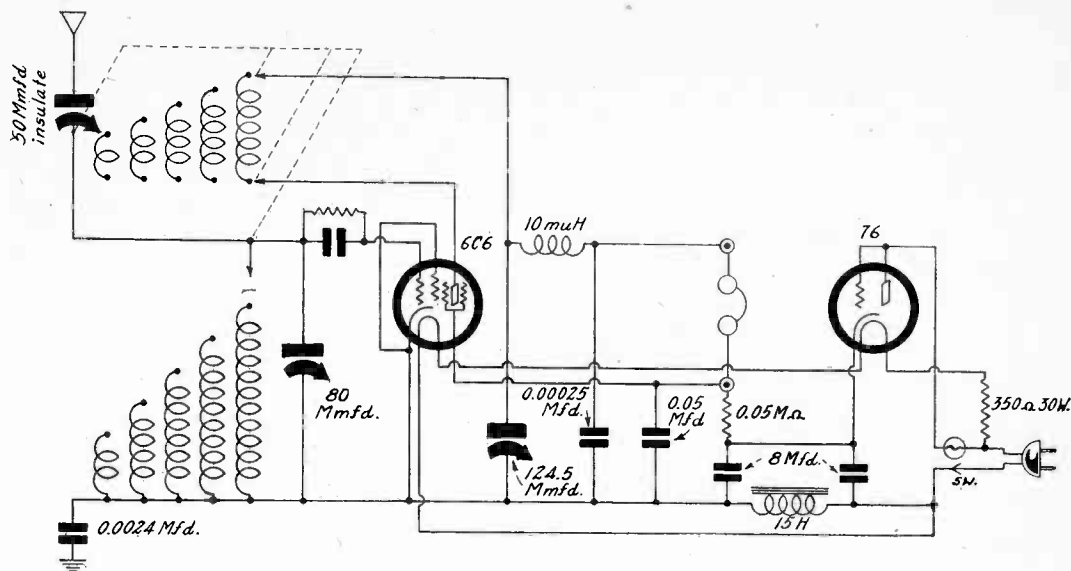

(Continued from preceding page)

reason why switching may not be used, as switches are being made much better now, have low contact resistance, small capacity, and sprung switch-settings so there is no need to ponder whether the coils are making contact at all.

### Automatic Series Adjustment

Besides, even the antenna series condenser, though it is variable, may be tied to the switch shaft, so that in effect there is a fixed capacity in series with the antenna, but a smaller fixed capacity for each band. If a condenser of 50 mmfd. is used at maximum for this purpose, and if the switch has five positions at 32.5 degrees displacement for each, there will be four differences, or a total displacement of 170 degrees, and the series capacity will be proportionate to the displacement, if a series condenser is used that has semi-circular plates. This is the straight-line capacity type of condenser.

For any given coil the frequency, with a series condenser for tuning, is inversely proportionate to the square root of the capacity. So even if a fixed primary for all bands were used, the series condenser at least would work in the right direction. But it is far preferable to proportion the primaries, if any are used, to the bands covered, although in general practice the primary is acceptably omitted entirely, and the antenna is coupled to the grid, without an extra winding, the medium of coupling being the series antenna condenser.

The reason for the inclusion of a series capacity in all of these circuits is to improve the performance of the receiver, which it does to a remarkable extent.

### Regeneration Throughout

In general, the higher the frequency to be received, the smaller the required capacity, and for the highest-frequency band, down to 15 meters or a little less (20 mc or higher), the capacity should be exceedingly small. Looking at the frequencies in the light of the required impedance, the capacity requirement is relatively as large in all instances, but is of course absolutely smaller for higher frequencies. So where 50 mmfd. would suffice for 1,600 kc, 10 mmfd. would be much more suitable for 16,000 kc.

One advantage of having a series capacity sensibly related to the frequencies to be received is that in a regenerative receiver there will be assurance of regeneration at any and all settings, for all bands. The actual value of the capacity, or setting of the condenser, is not critical, and therefore the change of capacity in fixed jumps, where a smaller capacity is used always for a higher frequency, is practical.

The method used in the receiver herewith is one of affixing an insulated-type flexible coupling unit to the rear protrusion of the coil-switch shaft, and inserting in the other side of the mechanical coupling device the shaft of the series condenser. This condenser must be insulated from the chassis, for neither side of the condenser is grounded.

While it is safe to use a maximum capacity of 50 mmfd. for the series condenser for the lowest-frequency band, starting somewhere around 1,600 to 1,700 kc, less may be used, by setting the condenser for less when the switch is set for the lowest-frequency band. Then the highest-frequency band would have less capacity than otherwise, but this is all right, for as little as 6 mmfd. may be used.

### Mechanical Precautions

One of the best practical tests for the selection of the setting,

since only one setting may be selected for establishing the absolute values of the rest of the fixed capacities, is to start the receiver going for the highest-frequency band, using no more series capacity than is necessary to insure oscillation. The condenser itself has a minimum of around 6 mmfd., so therefore even at apparent "zero-capacity setting," which, as stated, is well above zero, there will be adequate capacity for sufficient pickup of signal and for regeneration all over the dial. The only precaution to take is that the selection should not make the series condenser go beyond maximum, to turn again in the opposite direction for reduction, which is possible with condensers of the semi-circular-plate type, as usually they are not equipped with end stops. If there is an end stop, of course there must be no conflict between the switch and the end-stop, so that the switch is prevented from reaching one or more of its intended positions. The system has been worked with a switch, using six positions, so if only five positions are used there is scarcely any likelihood of trouble of this sort, particularly as switches in general have about the same angular displacement between settings, around 32 degrees.

### Highest-Frequency Coil First

The other important consideration is to see that the series condenser has its additional advantage fully protected, and that is avoidance of dead spots. If there is regeneration at all dial positions for all bands there will be no dead spots, so for the receiver under discussion the exposition regarding the regeneration test covers that of dead-spot-elimination.

It is possible that there is a dead spot and it is not noticed, therefore the wetted finger may be applied to the grid, and the experimenter can listen in the phones for the double plop, on plop, the first when the finger is touched to the grid, when oscillation stops, and the second when the finger is removed, when oscillation is restored.

The coils for the receiver may be wound on the small dowels used often for honeycomb coils. The diameter is  $\frac{3}{8}$  inch, and the length is about 1 inch. The first coil to wind is for the highest-frequency band, and this may consist of 20 turns of No. 20 enamel wire, sufficiently spaced to allow winding a tickler or feedback winding consisting of 15 turns of any fine insulated wire, such as No. 32 silk-covered, or the like. This interwinding of tickler and secondary is almost imperative for assurance of oscillation at the lower capacity settings of the condenser for this highest-frequency band, which will reach to about 15 meters.

The capacity used for tuning is 80 mmfd., to afford a frequency ratio of 2-to-1 for most of the bands, somewhat less perhaps for the highest-frequency band. So the next coil is wound experimentally so that at 5 or so on the dial (where numerical increase means more capacity) the same frequency will be attained as existed at 98 or so on the dial of the next highest-frequency band, the tickler being proportioned about the same way as before, and interwound. For the lower frequencies the same process is repeated, but if adequate insulation is put between windings, the interwound method need not be followed, but the tickler put over the secondary. The wire will have to be fine for the secondaries if enough to be put on for the lower-frequency bands, in the light of the small axial length of the coil.

### Small Diameters Sufficient

However, results will be productive, and in general, especially for the higher frequencies, the coils on the small diameters stand up very well. Their distributed capacities are

low, as these are proportionate to the diameter, but if spaced winding is used, as for the higher frequencies, the distributed capacities are proportionate to the radius. This is simply another way of stating that for spaced winding the distributed capacity is half of that for non-spaced winding. The distributed capacity is approximately equal in micro-microfarads to the diameter in centimeters of the form used, or, for spaced winding, the radius in centimeters of the form used. More strictly, the distance to be reckoned is the one between centers of wires rather than between opposite points of the circumference, etc., but where No. 20 wire is the largest used, this difference is not very serious.

The distributed capacity should be kept low because of the equivalent resistance introduced by the capacity between turns, and the sum of the capacities between turns, especially if the coil is short in length, compared to the diameter of the coil, for then the capacities are in a strongly localized magnetic field. The effect on the tuning ratio alone does not matter so much, in fact, if the distributed capacity did nothing more than cut down the ratio it would be advantageous at the high frequencies to keep that capacity high, since a smaller ratio for a higher-frequency band of tuning is desirable as a sort of band-spread effect, that is, affording better mechanical separation on the dial for stations tuned in.

**Leak-Condenser Valves**

The frequency ratio depends also on the proximity of the coil to any metal objects, to the presence of shielding, complete or partial, and even to the values of leak and condenser. These values should be selected on the basis of the highest-frequency band to be tuned in, so there will be no grid blocking anywhere on this band. An audible sound in the phones, perhaps a drone, a whistle, or even only a severe pop somewhere near the highest frequency attainable, will disclose grid blocking. A meter in the plate circuit will disclose it, too, for the plate current becomes reduced to a very small value indeed when blocking takes place, so small in fact that the condition is also described as saturation, which means that practically all of the utilized electrons emitted from the cathode flow in the grid circuit as grid current, the space charge in the tube neutralizing the flow of electrons that otherwise would take place from cathode to plate. This condition is also stated to be "cutting off of plate current," although of course there is some plate current, but it is far too small, and the tube practically stops its useful operation. Whenever there is any potential difference across a resistance, and the tube for this purpose may be regarded as a resistance, there is some current, however small, and the condition described as "stoppage" is merely relative. But the stoppage of the signal, in which we are most interested, is almost absolute.

The leak and condenser therefore would be selected of lower values than for broadcast reception. If a series leak is used, with condenser across it, as here, then the leak may have a value around 0.05 meg. (50,000 ohms, five-one-hundredths of a megohm), and the condenser may be 0.00025 mfd. to 0.0001 mfd., or may be even smaller.

**Test of Values**

An excellent practice is to put in the plate circuit a milliammeter of sufficient sensitivity to give a reading where it can be discerned well without trouble, thus enable close determination of differences, and a 0-1 milliammeter usually suffices, then put a mica-dielectric condenser of 0.001 mfd. or higher capacity across the meter, and, using 0.0001 mfd., select a leak value that gives

practically the same plate current for all frequency settings on the highest band of frequencies. If the current increases at the lower capacity settings of the tuning condenser, either reduce the value of the leak or increase the capacity of the condenser.

It is not always better practice to use the highest possible leak value with the smallest possible condenser, or with any particular capacity condenser, because the leak acts as a radio-frequency damper and injures selectivity at low tuning capacity, and this damping effect is offset by the grid condenser, and the higher capacity of the grid condenser, the greater the offsetting of the damping, except that when the condenser is too high, as it soon will be, grid blocking occurs, because the time-constant of the leak-condenser circuit is too low.

When the double-plop test is made, the second plop, designating restoration of oscillation, should immediately follow removal of the finger, and there should be therefore no appreciable lag or delay, for this denotes too low a time constant. In a way the method is a qualitative measure of the time constant, which is the resistance in ohms multiplied by the capacity in farads. This value is a reciprocal of frequency. Thus for 0.0001 mfd. and 50,000 ohms the product is obtained by multiplying 0.000,000,000,1 farad by 50,000, equals 0.000,005 second (5 micro-seconds), and the frequency is 200,000 cycles. This being far above audibility, no modulation will be present in the form of interference, such as a howl, screech, whistle, drumming or plopping as accompanies grid blocking.

The leak and condenser properly chosen, and the tuning effect of the series antenna condenser being a fixture for any band, frequency calibration becomes practical except so far as affected by throttle condenser (124.5 mmfd.) setting.

**Line Safeguards**

The circuit is shown in its simplest form, and there are only the detector tube and the rectifier of the a-c line voltage, which rectifier is floated on the line when d.c. is used, for this is a "universal" type receiver. The limiting resistor for the heater circuits is selected on the basis of a 115-volt line. For a line of twice that voltage the resistance would have to be doubled (700 ohms) as well as the wattage doubled (60 watts instead of 30 watts).

The phones should be of the high impedance type for maximum sensitivity, around 7,000 ohms or so, rather than the low-impedance type, of around 2,000 ohms, although the circuit works on both types of phones. There are some phones made with an impedance of 20,000 ohms, and these probably would afford maximum sensitivity.

The B supply choke is placed in the negative leg, and the ground connection is made through a mica condenser of 0.00024 mfd., value not critical. These two selections are made on the basis of eliminating any danger from a short due to grounding of the metal cabinet, if one is used, for an accidental short would do no harm if the lower side of the line, at the plug, were grounded, due to the lighting company's hookup, and the left-hand side of the choke, because accidentally grounded, were connected to the same point. The choke would be shorted out of service, because of no potential difference across it, but the line protected. If the positive side of the line is grounded (assumed to be the upper branch in the diagram), and were connected accidentally to chassis due to ground wire touching the metal, the choke simply would be across the line, and as it has sufficient impedance, no harm would result. But the 8 mfd. condenser between cathode of the rectifier and the line must have its negative side insulated from the chassis. This is the right-hand 8 mfd. condenser in the diagram, and is an electrolytic.

**A THOUGHT FOR THE WEEK**

**D**R. LEE DE FOREST, of Los Angeles and Radioland generally, has been telling representatives of the press that television sets will be sold next year at prices ranging from \$200 to \$250. He has not announced this as a mere hope but as a definite conviction. If taken seriously—and, after all, Dr. De Forest is not exactly a tyro in the radio game—the whole radio trade field should become excited and manufacturers of even the most successful of sets now popular should groan aloud in spasms of pain and apprehension.

How different is Dr. De Forest's conclusions from those of Vice-President Baker of the RCA Victor Company, who declares that an investment of \$80,000,000 would be necessary for the installation and maintenance of the transmitters necessary for nationwide service.

As Mr. Baker bluntly asks: *Who is to furnish the \$80,000,000?* Perhaps Dr. De Forest can give him the answer—just like that!

**Literature Wanted**

*Readers desiring radio literature from manufacturers and jobbers should send a request for publication of their name and address. Address Literature Editor, RADIO WORLD, 145 West 45th Street, New York, N. Y.*

- W. J. Coombe, 1358 Thoreau, Lakewood, Ohio
- A. C. Schaefer, 1211 N. McCadden Place, Hollywood, Calif.
- John M. Meier, 408 N. Blackhoof, Wapakoneta, Ohio
- Lankford Electric Co., Britton, Okla.
- Geo. M. Millar, Vancouver School Board, 519 Hamilton St., Vancouver, B.C., Canada
- Ross Williams, 325 Redington Ave., Troy, Penna.
- G. R. Webber, P. O. Box 965, Plainfield, N. J.
- M. E. Snyder, 1047 Gordon St., Toledo, Ohio
- W. P. Hewer, Greenstreet, Sask., Canada
- J. J. Black, 1773 Marks Ave., Akron, Ohio
- Alphonse Marquis, 120 Lowell St., Lawrence, Mass.
- Mason E. Redman, 1822 W. 108th Place, Chicago, Ill.
- Eugene P. Tetreault, Pascoag, R. I.
- Thos. Hill Nicholl, 1779 Middlehurst Road, Cleveland Heights, Ohio
- R. O. Young, 720 Haight St., San Francisco, Calif.
- Dr. Spencer Carleton, 75 Whitestone Ave., Flushing, N. Y.

**SUBSCRIBE NOW!**

**RADIO WORLD**  
145 W. 45th St.  
New York City

Enclosed please find my remittance for subscription for RADIO WORLD, one copy each week for specified period.

- \$10.00 for two years, 104 issues.
- \$6 for one year, 52 issues.
- \$3 for six months, 26 issues.
- \$1.50 for three months, 13 issues.
- \$1.00 extra per year for foreign postage.
- This is a renewal of an existing mail subscription (Check off if true)

Your name.....

Address .....

City .....

# How Tubes Behave

## An Exposition of Functions and Performance

By J. E. Anderson and Herman Bernard

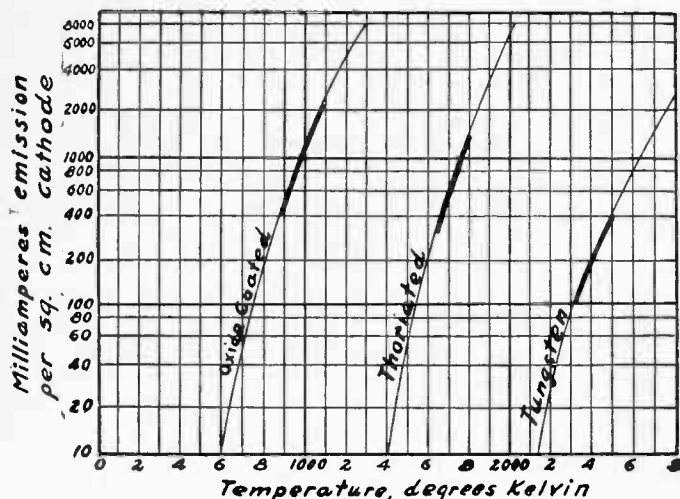

FIG. X-1

The variation of emission with change of temperature for three different emitters.

REFERRING to Fig. X-3 it will be noticed that the four curves are of the same form and that they differ only in position with respect to the origin. There is a constant separation between the curves when the plate voltages differ by the same amounts.

The amplification factor of the tube can be obtained from the mutual curves. By definition it is the ratio between the change in plate voltage to the change in the grid voltage necessary to keep the plate current constant, the understanding being that very small changes are involved. Let us attempt to get the amplification factor from the curves in Fig. X-3. Let the current be held constant at 110 milliamperes. When the grid voltage is zero the voltage required on the plate to make the current the value we have selected is 100 volts. When the plate voltage is 200 volts, the plate current is 110 milliamperes when the grid voltage is 25 volts negative. Thus if the plate voltage is increased by 100 volts, from 100 to 200, the plate current is restored to its former value by changing the bias 25 volts. The negative bias must be increased when the plate potential is increased in order to keep the current constant. Now, 100/25 equals 4, and consequently the amplification factor of the tube is four when obtained under these conditions. The method of deriving the amplification factor follows the definition with the exception that large values were used instead of very small. Yet the error in the value obtained is very small, judged by the values given in Fig. X-2.

### Plate Characteristics of a Triode

When the plate current is measured at a fixed bias and at different values of the plate potential, and if this is done for many different bias values, a family of plate current, plate voltage curves is obtained, as is shown in Fig. X-4. As in the case of the mutual curves in Fig. X-3, these curves are all alike and equally spaced when the grid bias increases in equal steps. The spacing depends directly on the amplification factor, for it can be obtained from the curves by applying the definition. The result, however, is not accurate because the curves have not been plotted accurately and the scale is not easily read.

A load line representing a load resistance of 2,500 ohms has been drawn across the family of curves in Fig. X-4. The operating bias is indicated by a dashed line marked 43.5 volts. The intersection of this line with the load line indicates the steady plate current in the tube when no signal is impressed, and this current is approximately 60 milliamperes. When a signal is expressed the current varies from instant but it follows the load line. If the amplitude of the signal is equal to the bias, the instantaneous grid potential varies between zero and 87 volts and the plate current varies between about 12 and 120 milliamperes. Simultaneously the effective plate voltage varies between 105 and 362 volts.

By the total variation in the plate current and the plate voltage, it is possible to compute the output power that is expended

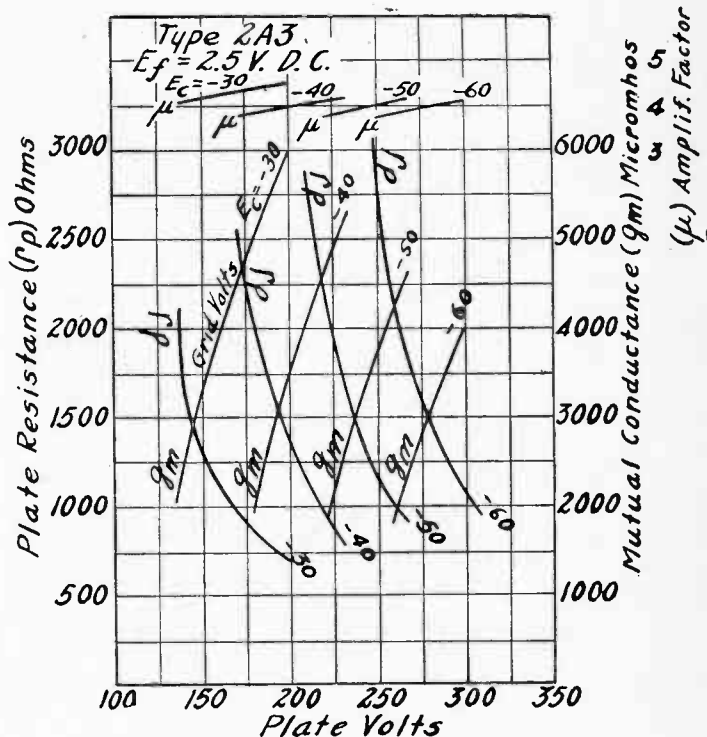

FIG. X-2

These curves show the variations in the amplification factor, the mutual conductance (transconductance), and the plate resistance of a power triode.

in the 2,500-ohm resistor. Since the total change in the voltage is 257 volts, the amplitude of the voltage changes is 128.5 volts. Similarly, the amplitude of the current change is 54 milliamperes. One-half of the product of the amplitudes is the power. Therefore the power is 3.5 watts. This agrees with the rated output power of the 2A3 tube, to which the curves pertain.

The plate resistance of the tube can also be obtained from the curves in Fig. X-4. By definition the plate resistance is the ratio of the plate voltage change to the corresponding plate current change, the grid potential remaining constant. Strictly, the changes involved should be small. Let us consider the curve for which the grid bias is minus 10 volts. When the plate voltage is 200 volts, the current is 213 milliamperes. Again, when the plate voltage is 150 volts, the current is 120 milliamperes. The voltage change is 50 volts and the corresponding current change is 90 milliamperes. Therefore the plate resistance is 50/0.09, or 560 ohms. This does not agree very well with the rated value of 800 ohms, but that is because the curves have not been plotted accurately nor on a sufficiently large scale to allow close readings.

### Properties of Screen Grid Tubes

When the thermionic tube is a tetrode and the fourth element, surrounding the plate, is given a positive voltage, the characteristics of the tube are altogether different from what they are in the triode. A typical family of plate voltage, plate current curves is reproduced in Fig. X-5, the tube in question being the 24-A. As is indicated, the screen was maintained at a fixed potential of 90 volts, while the plate voltage was varied from zero up to 560 volts. Curves have been taken for six different grid bias voltages from zero to 7.5 volts. In addition to the plate current curves, one screen current curve is shown.

There is a region of unstable values of plate current, which is that for which the plate potential is lower than the potential applied to the screen. For very low plate voltages the plate current increases to a low maximum. Then it suddenly decreases until it reaches a rather high minimum. The peculiar thing about this part of the characteristics is that the current is negative; that is, it flows from the plate and not to it. Beyond the minimum the current rises rapidly up to the point where

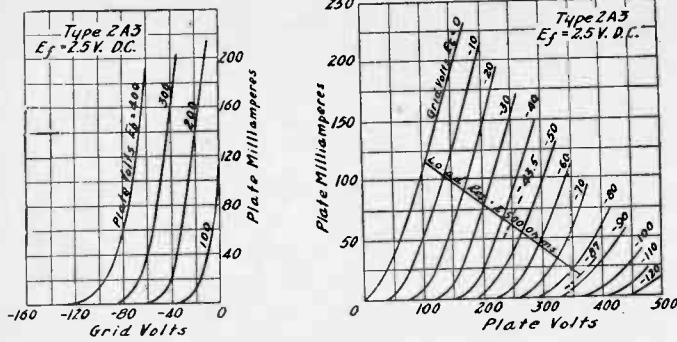

FIG. X-3

Characteristics of a power triode. At left are grid voltage, plate current curves and at right plate current, plate voltage curves.

the plate voltage is approximately equal to the screen voltage, and after that the increases in the plate current is slow or practically zero.

The useful range of the family of curves is that above the screen voltage, or even above 120 volts on the plate. In this useful region the change in the plate current is entirely different from that in the triode. In the tetrode it is the change in the grid voltage that causes a large change in the plate current, while in the triode there was a large change in the plate current with change of plate voltage as well.

In using the tetrode the applied plate voltage, the screen potential, and the load resistance should be such that at no time during the signal voltage cycle the effective voltage on the plate should become less than the screen potential. To attain this the plate load resistance should be low for fixed values of screen and plate applied potentials, the applied plate voltage should be high for fixed values of screen potential and load resistance, and the screen potential should be low for fixed values of applied plate potential and load resistance. In other words, if a load line is drawn across the curve for zero bias on the right of the point where the curve suddenly drops. This is true both for amplification and detection. If these points are not observed distortion will result in the output whether the tube is used for amplification or for detection by the bias method.

Dynatron

Above the current maximum at about 10 volts plate potential and the minimum at about 50 volts, the plate current decreases as the plate voltage increases. That is, the slope of the curve in this region is negative. Since the slope is a conductivity, the reciprocal of resistance, it is usually said that the tube has a negative resistance characteristic in this region. The main application of this property of the tetrode is to the dynatron oscillator. The best plate potential for this application is approximately 20 volts positive, the screen being 90 volts positive. It is immaterial what the grid bias is, but if it is too high the tube will not oscillate. Just what the maximum bias may be without stopping oscillation depends on the excellence of the parallel tuned circuit that is connected between the plate and B plus or the cathode. The better the circuit is the higher the bias may be without stopping oscillation.

The reciprocal nature of the screen current variation is of interest. Where the plate current is maximum, the screen cur-

rent is minimum; where the plate current is minimum, the screen current is maximum. Where the slope of the plate current curve is maximum, the slope of the screen current is also maximum, but in the opposite sense. Indeed, at every point the slopes of the two curves have opposite signs. It is clear that the screen takes a toll of the electrons and that the percentage of the total number that it takes depends on the relative values of the potentials on the elements involved.

We mentioned the fact that for certain plate potentials the current flowed from the plate to the cathode rather than in the opposite direction as usual. How can this come about? The plate is not an emitter, for it is not hot enough, and the plate is positive with respect to the cathode, even though it is negative with respect to the screen. The cause of current flow in the wrong direction is secondary emission. The plate does emit electrons, but only as a result of bombardment of electrons on the plate. Electrons are given a high velocity by the potential of the grid and they are hurled forcefully against the plate. The impact releases more electrons and these are attracted to the screen because the screen is at a higher positive potential than the plate. Therefore, notwithstanding the electrons that are hurled from the screen to the plate, more electrons move in the other direction, and thus the plate current is negative. It is the screen that gains these extra electrons, as may be seen from the high screen current peak at the voltage at which the plate current has the largest negative value.

Tubes with Suppressor Grids

The unstable characteristics of the tetrode for low positive values of plate potential impose serious limitations on the use of the tube. The advantages of the screen grid are supposed to be very great, yet they are largely fictitious because of the irregularities of the curves in the region of low plate potentials. Since the cause of the irregularities is the secondary emission from the plate, if this can be suppressed the theoretical advantages of screening could be realized.

Secondary emission is suppressed by means of a suppressor grid placed near the plate, that is, between the plate and the screen grid. The potential on the suppressor may be either zero or negative and for this reason it does not exert a strong attraction for the electrons. If it is negative, of course, it repels them. Since the suppressor is a grid, it also prevents the screen from exerting its full attraction on the electrons released by impact on the plate. The result is that no electrons have a chance to travel from the plate to the screen for any positive potentials on the plate, for those that are released by impact of incident electrons immediately fall back into the plate.

The effect of the suppressor grid is strikingly brought out by a comparison of Figs. X-5 and X-6. The first of these, as has been said, is a family of plate current, plate voltage curves for a tube that has a screen but no suppressor, while the second is such a family for a tube that has both a screen and a suppressor. The irregularities of the curves in the low plate voltage region have disappeared entirely and the useful range has been extended to plate voltages less than the screen voltage. The screen voltage, as indicated, is 67.5 volts and the minimum permissible voltage on the plate is about 40 volts.

Tube Structures

An idea of the different arrangements of the tubes elements may be gained from Fig. X-7. At the left is an ordinary triode structure in which the control grid, G, is placed between the cathode, K, and the plate, P. In the middle of Fig. X-7 we have the arrangement of the elements in a tetrode. The cathode is at the left, then the control grid, then the screen, then the plate, and once more the screen. That is, the screen surrounds the

(Continued on next page)

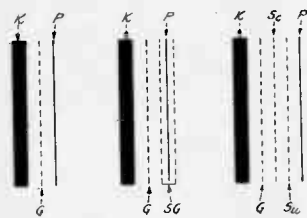

FIG. X-4

Relative positions of the elements: Left, triode; middle, tetrode; right, pentode. Structures may be cylindrical or plane, both being commonly used.

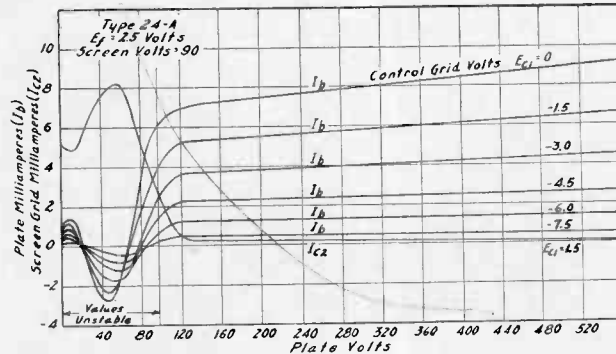

FIG. X-5

A family of plate voltage, plate current curves for a typical tetrode tube, showing the irregular plate current at low voltages, due to secondary emission of electrons from the plate.

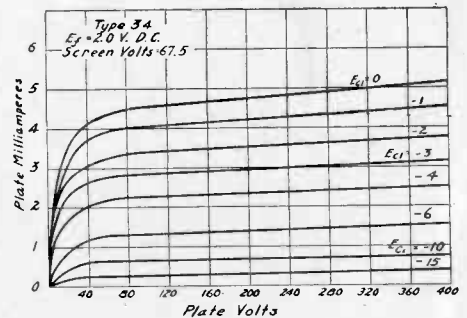

FIG. X-6

A family of plate voltage, plate current curves for a typical pentode radio-frequency amplifier tube in which the plate current irregularities have been removed by the suppressor grid.

(Continued from preceding page)

plate. It is not essential, however, to the screen grid tube that the plate should be surrounded by the screen, for it suffices that it be between the control grid and the plate. At right in Fig. X-7 is shown how the suppressor tube is constructed. The control grid is next to the cathode, then comes the screen, then the suppressor, and finally the plate.

The amplification factor in a triode structure depends on the relative distances between K and G and G and P and also on the closeness of the mesh of the grid. The closer the grid is to the cathode and the tighter the grid mesh, the greater is the amplification constant. The amplification factor in the tetrode and pentode structures depends largely on the relative voltages applied to the elements; and since the voltages may have any values, large variations must be expected in the amplification factors of these tubes. As an illustration, if the amplification factor of the -34 super-control tube, the plate characteristics of which are shown in Fig. X-6, is 224 when measured at 67.5 volts on the plate, 360 when measured with 135 volts, and 620 when measured with 180 volts on the plate, in each case the screen voltage being 67.5 volts and the grid bias -3 volts.

### Gain Obtained

The gain obtained from a tube depends on the relative values of the internal plate resistance and the load impedance, as well as on the amplification factor. The higher the load impedance, whether it be pure resistance or reactance, the higher the gain, but it will never reach the amplification factor. In a tetrode or pentode the gain is the product of the transconductance and the load resistance, but this holds only when the transconductance used is that measured at the effective value of the plate potential. This is much less than the listed transconductance. In any case, however, it is true that the higher the load impedance the higher the voltage gain.

As long as the frequency is low, the capacities between the elements do not affect the operation of the thermionic tube appreciably. However, as the frequency increases these capacities have a greater and greater effect, and in the radio-frequency band, and higher, they play an important role. In most applications of the tube the inter-electrode capacities are detrimental, while in others they are essential. But even in cases where they are essential, as well as in all cases where they are detrimental, it is desirable that they be as small as possible.

In order to gain an insight into the problem of inter-electrode capacities let us consider the structure of the tubes. In Fig. X-2 we have a representation of a triode, the right-hand figure showing the relative positions of the three electrodes and the left-hand figure showing the equivalent network of condensers. Each of the three elements, the plate, the grid, and the cathode, is a conductor of definite physical dimensions. Hence it has electrostatic capacity with respect to its surroundings, and there is an electrostatic capacity between any two of the elements. Since G is a screen between the plate and the cathode, as is indicated by the right-hand figure, we would expect that the capacity between the plate and the cathode is very small, but this is not necessarily so because the grid is not a complete screen. Just what the values of the inter-electrode capacities are depends on the purpose of the tube. For example, a 2A3 power tube has the following values:  $C_p=4$ ,  $C_g=9$ , and  $C_m=13$  mmfd. Here the grid-plate capacity is much the largest. A 75 high mu tube, on the other hand, has the following values:  $C_p=3.8$ ,  $C_g=1.7$ , and  $C_m=1.7$  mmfd. For this tube, then, the plate-cathode capacity is much the largest. These tubes are extremes of the triode type, the 2A3 being a low-mu power tube and the 75 being a high-mu voltage amplifier.

### Effect of Capacities

That the inter-electrode capacities affect the performance of the tube adversely becomes clear after a little consideration. Suppose, for example, that the tube is operated in a resistance coupled circuit. There will be a high resistance across  $C_g$  through which a current will flow. Since the condenser is in parallel, the total current will divide between the resistor and the condenser inversely as their impedances. For high frequencies more will flow through the condenser than through the resistor, and the voltage drop across the combination will be less for the high frequencies than for the low. The condenser  $C_g$ , therefore, will cause a frequency discrimination which may become very serious in a high quality circuit. And this is not all, for  $C_p$  in the plate circuit will have a similar effect, and even  $C_m$  will reduce the amplification more on the high frequencies than on the low, provided the load on the tube is not positively reactive.

The greatest effect of  $C_m$  occurs in high-frequency circuits when the plate circuit is tuned to the frequency of the signal voltage, or to a frequency close to it. The plate circuit may then be highly inductive and self-oscillation may result. The input and output condensers,  $C_g$  and  $C_p$ , work in opposite direction to  $C_m$  in respect to oscillation and regenerative amplification. One reason why a tube having a screen will not oscillate so readily because of feed-back through  $C_m$  is that  $C_g$  and  $C_p$  are large, but the main reason of course is that  $C_m$  is extremely minute.

It is only when the inter-electrode capacities enter essentially

# 45 Henrie Constitute Filter in Un

By Lee I

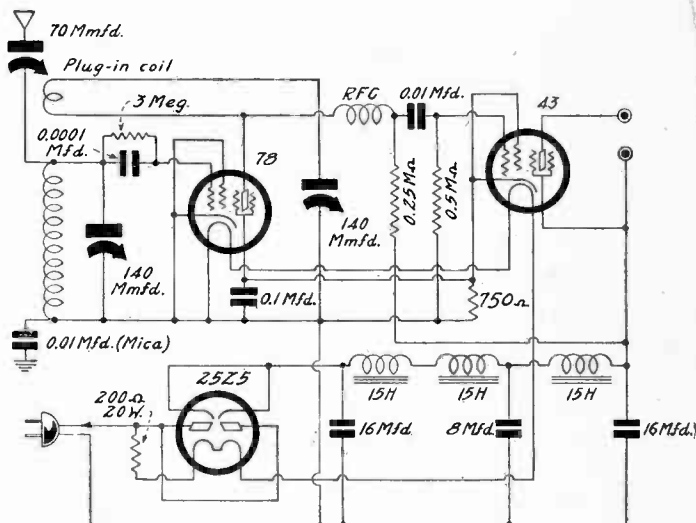

Three-tube short-wave universal circuit

HERE we have a universal set, that is, a set that will work either on an alternating or a direct current line without any change in the wiring. There is a plug of the same type as that used for a toaster, or a curling iron, or washing machine; it is inserted in the nearest outlet; the set plays. It is not necessary to find out whether the current is alternating or direct. Now this is a great convenience, for not many would know how to determine what kind of current is supplied over the wiring without asking the electric company.

What kind of set is this universal? This particular universal contains three tubes, one a 78 super-control tube, used as regenerative detector, another a 43, used as a power tube, and still another, the 25Z5, used as rectifier when the power supply is such that a rectifier is needed, and only floats on the line when it is not necessary as a rectifier.

Let us examine the heater circuit to see whether we can discover any cogent reason why this particular combination of tubes has been used. There is the 25Z5 rectifier tube.

It requires a filament or heater voltage of 25 volts and a heater current of 0.3 ampere. By themselves there is nothing in these facts to show why the 25Z5 was chosen in place of some other rectifier tube.

### Economical Theatre Design

If we continue we note that the 43 also is a 25-volt, 0.3-ampere tube. We have partly solved the mystery, for we have found a repetition. If we add the voltages required we find that the two tubes require 50 volts and a current of 0.3 ampere. Well, as far as we have gone the design of the heater circuit has been economical. We can conclude, therefore, that that was at least one object for choosing these tubes.

If we look in a tube book we find that the 78 requires a current of 0.3 ampere and a heater voltage of 6.3. The total useful voltage in the heater then is 56.3 volts. Now it is highly probable that the line voltage will be 115 volts, on the average. Therefore there is an excess of 58.7 volts, which must be dropped somehow.

We cannot find any useful application for it, but we must get rid of it anyway. Therefore we put in a ballast resistor, one that will drop 58.7 volts when 0.3 ampere flows through it. A resistor of 195 ohms will do that. There is, however, another condition that this resistor must satisfy: it must dissipate 17.6

into an oscillator circuit that they are advantageous. Illustrations are the ultraudion and the Barkhausen-Kurz oscillators. Fig. X-7 does not show where all the inter-electrode capacities



# s, 40 Mfd.

## Universal Short-Wave Set

**Mumford**

watts without setting the set on fire or even without getting dangerously hot. The least rating that we ought to tolerate is 20 watts, and it may be that it is not necessary to use a much heavier one, especially if it is placed judiciously in respect to delicate objects in the receiver. Now, there is not likely to be a 195-ohm resistor of this rating, but it is a good bet that a 200-ohm resistor of this rating can be found. And that is all right.

We have finished the heater circuit, assuming that we have connected the tube heaters in series with each other, in series with the ballast, with the line switch, and with the line.

There are two cathodes in the 25Z5; they are tied together. There are also two plates; they, too, are tied together. In other words, we treat the dual tube so that we only get one tube out of it. The object of that is to get a tube of double the capacity. Well, one side of the line is connected to the joined plates, with nothing between but the switch. Now, since the plates, or anodes, must be positive, it is the positive side of the line that is connected to the plates in case the supply is direct current. If it is alternating, simply one side is joined to the plates, for which ever side is selected, it is positive half of the time.

There is only one side left of the line and we have the two joined cathodes. No, no, we do not make the connection. We connect the cathodes to a 16 mfd. condenser, electrolytic of course, and also to one side of a 15-henry choke coil. There is another 15-henry choke without the benefit of a shunt condenser, and there is a third 15-henry choke, but this time we wring the condensers in. First, there is an eight from the junction of the two last 15-henry chokes to ground—or rather to the negative of the line, and at the end there is a second 16 mfd. electrolytic from plus to minus.

### Good Combination

This combination strikes us as a very thorough filter—45 henries and 40 mfd. Well, it may be needed, not if the hum is merely to be reduced to the limit of toleration but if it is to be banished from the set without even a trace. We cannot say definitely that in all instances this happy result will ensure, for there are too many conditions that may bring about hum, some of which conditions no filter satisfy. The devious vagaries of a universal receiver cannot be provided for. Still there is an excellent chance that hum will not make itself heard even when the regeneration is pushed to the utmost limit, and Prompt Radio Company found the results hum-free.

More could be said about filtering, for we have not even mentioned all of it yet; but we shall turn to regeneration while that is fresh in the mind.

Yes, the circuit is regenerative, and perhaps the best thing about that is that there is a total absence of novelty about it. In other words, a well-tried method of regeneration and of its control has been selected. The feedback is by tickler coil and the control is by variable condenser in series with the tickler. And the rotor of that control condenser is grounded, which fact removes all ticklishness out of the tickler. It is substantial, dependable, and positive. It is entirely free from the Therman effect. The plate is parallel fed but there is a radio-frequency choke that prevents short-circuit. Somehow, that feature, too, sounds familiar.

There would be little regeneration if the antenna were coupled closely to the tuned circuit, because the antenna would introduce so much resistance that the tube could not carry the load. We may assume without further ado that the coupling is not close. The fact is that it is very loose. There is plenty of regeneration as a consequence. It is the 70 mmfd. condenser that accounts for the looseness of the coupling. Since this condenser is variable, the operator is at liberty to select any degree of coupling that suits his fancy. Naturally, this fancy will be that coupling which will give the best combination of selectivity and sensitivity. It is a strange fact that greater sensitivity should result, together with stronger signals, when we choke up the input so that only a small fraction of the signal is brought to the detector, not counting the regeneration. But it is true.

come from because the leads to the active elements have been omitted from it. A very considerable part of the capacity, if not the greater part, comes from the leads, and this fact is brought

out clearly in Fig. X-8. In this figure (a) is a wire which holds the "getter" cup. It is attached to (b), the supporting wire for the center of the filament. Both (a) and (b), therefore, are at the potential of the center of the filament, that is, cathode. The physical disposition of these wires is such that they do not add much to the capacities. The two arrow-terminating wires F are for the filaments, and they continue down to the prongs. Next to the filament wires are the grid leads, one, on the left, terminating in the press and the other continuing down to the prong. The outside leads, marked P, or the plate leads; one terminates in the press and is used for support only while the other continues down to the prong and serves both for support and for leadin.

It is clear that there is considerable capacity between the wires for they not only run parallel a short distance but they also are close together. It is only in the press and above where the capacity is high for below the press the conductors separate and go to the prongs. The arrangement shown in Fig. X-8 is that for the —30 tube.

For ultra-short-wave circuits leads from the prongs to the active elements not only have appreciable capacity but also inductance, and both must be taken into account. If a tube is used as oscillator at a very high frequency, both the distributed inductance and capacity must be reduced to the lowest possible value. While a high inductance is required for efficient oscillation it is best to have this inductance outside the tube where it can be controlled.

### Variation in the Capacity

When an oscillator is first turned on there is a period during which the frequency is continually changing, and this change does not cease until the tube has gained its final temperature. That this change should occur is not surprising when we remember that the inter-electrode capacities are part of the frequency-determining circuit, one of them being directly in shunt with the tuning condenser in the resonant circuit and the other two being in series with each other and then in shunt with the tuning capacity. But what makes the frequency change? Because these capacities change during the warming-up period. Why they should do so is clear from the tube structure. As the temperature increases the dimensions of the tube increase and the distance between any two elements increases and at the same time the size of the conductors increases. One of these changes, that is, increasing separation, tends to make the capacity smaller, while the other, increasing size, tends to make the capacity larger. Which of these is predominant is difficult to say but it is an experimental fact that the changes occur. Inasmuch as capacity in the electrostatic system of measurement is a length it is reasonable to suppose that, in general, capacity increases as the temperature increases. This would cause the frequency of oscillation to decrease with increasing temperature.

While the effect of capacity change is mostly noticeable when the oscillator is first started, it is present all the time. The ambient temperature may change frequently and each time it changes there is a change in the temperature of the tube elements. There may also be changes in the heating current, or in the plate current, or in the radiation, each of which will be reflected in the temperature of the tube elements and in the frequency of the oscillator.

[The foregoing is an instalment of "The Short-Wave Authority."]

## Tube Capacities Play An Important Role in Short-Wave Work

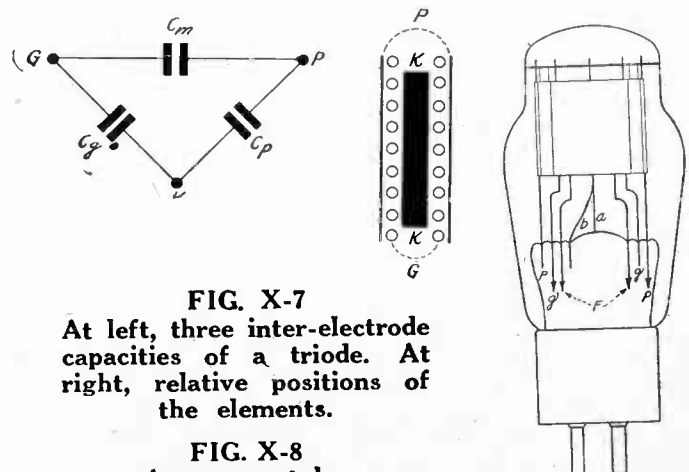

FIG. X-7  
At left, three inter-electrode capacities of a triode. At right, relative positions of the elements.

FIG. X-8  
A vacuum tube.

# Hum Elimination in Self-Contained Short-Wave Set

By Roger Prior Dolling

**H**UM in a-c operated short-wave receivers has been given considerable attention, and some concession to its existence is found in the fact that there are short-wave tuners with separate B supplies. The idea is that the farther away the B supply is from the receiver proper, the less likelihood of coupling the hum frequency of the line to any part of the tuner, particularly the highly-sensitized detector in a regenerative circuit.

There are various ways of coping with the hum problem. One of them is to use much larger capacities in the filter than ordinarily. Thus next to the rectifier there may be 16 mfd., then a mid-section condenser may consist of 8 mfd. and the reservoir or tank condenser also of 16 mfd., this being the one at the end of the filter. Within limits this method has advantages, but the point is reached when the addition of capacity increases rather than decreases the hum, and each circuit has to be treated from this special aspect. It is no difficult problem properly to apportion the capacities, but the rule that the higher the capacity, the less the hum, does not hold strictly. Another method is to employ the tuned choke.

## Adequate Inductance Needed

In considering the capacities one must not neglect the inductance. If there is small B current through the choke, the actual inductance is higher than if there is more current, for iron-core chokes are used, and the core becomes saturated,

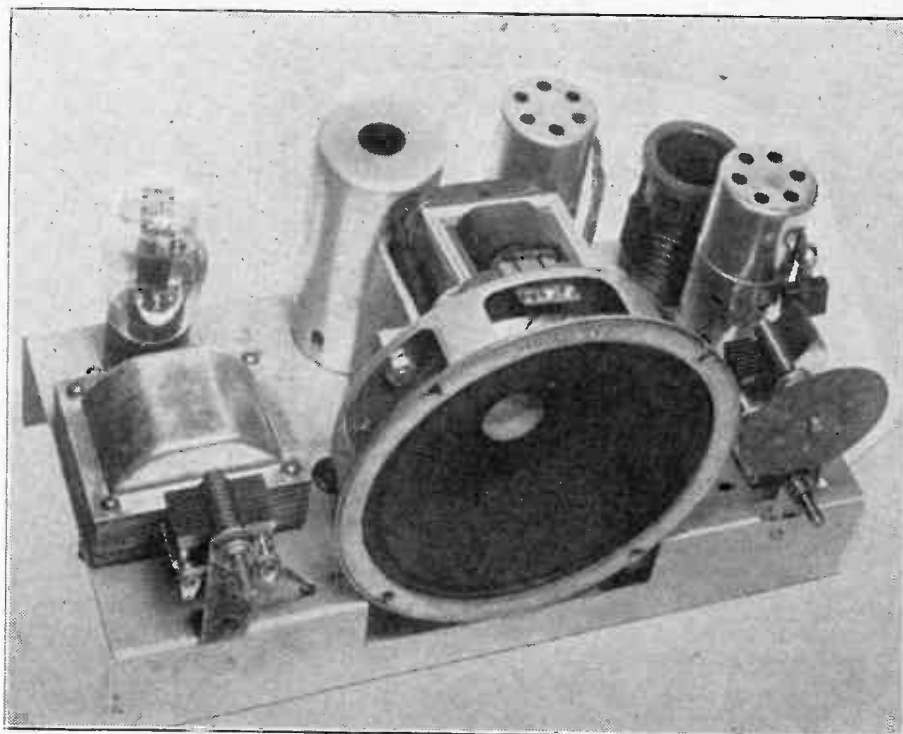

View of the completed receiver

meaning that all the lines of magnetic force which the core is capable of stand-

ing are present. While it is easy to increase capacity—simply add a condenser, or use one of higher capacity—there is no ready means of compactly attaining high inductance values, so hum may be due largely to 5-henry chokes being used where 30 henries would be required.

## Tuned Choke Effective in Squelching of Hum

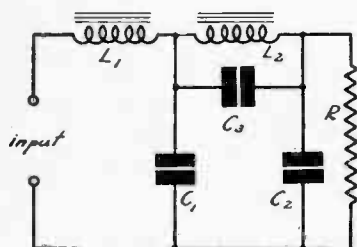

A tuned filter in which the second choke is tuned to the ripple frequency by an adjustable condenser C3. Choke input insures elimination of the higher harmonics.

An effective filter that will almost completely eliminate hum is shown in the figure. The terminals marked "input" are to be connected to the source of voltage to be filtered, and the source may be a thermionic rectifier like the 80, the upper terminal being connected to the positive filament and the lower to the center of the high-voltage winding of the power transformer.

The circuit is "choke input," that is, the first thing the current encounters in the filter is an inductance coil L1. The fact that the first element is a choke in series cuts the output voltage but it protects the

rectifier tube and also the filter condensers.

The two condensers C1 and C2 are the usual shunt condensers in a filter, which may be as large as 8 mfd. each to good advantage, although smaller condensers will serve when necessary to use them. Perhaps the most important part of the filter is the second choke, L2, and the condenser, C3, across it. The condenser is so adjusted that it resonates with the choke at the principal ripple frequency, that is, 120 cycles per second when the line frequency is 60 cycles and the rectifier is full-wave.

It is necessary to tune this circuit experimentally because it is difficult to predetermine either the inductance of the choke or the capacity of the condenser. The proper value of the condenser can be found readily by building up the condenser out of smaller units, one of which, during the period of adjustment, may be a variable air condenser. If such is used, the capacity range should be larger than the capacity of the unit fixed condensers out of which C3 is built up. Ultimately, there need be only one condenser, for the composite condenser may be replaced by one condenser of the same capacity. However, there is nothing against using the composite condenser just as it is found, except, perhaps, the air condenser. This can be replaced by a compression type variable condenser adjustable to the necessary capacity.

## Capacity Alone

It is possible to filter with capacity alone, though not so well, so the smaller the choke inductance, the closer the approach to exclusive capacity filtration.

In considering hum the tube that bears close watching is the detector. Everybody knows that there is hum in the line rectifier, for the hum-frequency is put right into that tube; also everybody knows that the intention is to eliminate as much as possible of this hum by filtration of the orthodox style. But there are some additional and extremely valuable methods, not so generally used.

## Grid Circuit Filter

One of these is the resistance-capacity filter. It will be found that if a circuit, instead of being returned directly to B minus or ground, has a series resistor of considerable magnitude, and if a condenser is put between the high side of this resistor and ground or B minus, or in many instances to the common point of both, the hum reduction will be considerable. The reason is that the effect of the capacity is increased the higher the resistance and thus hum frequency is detoured from some of the static load. One might define the static load as that load through which d.c. would pass, and thus include all adjuncts from which the signal was eliminated by a capacity. The hum frequency, which for the line is commonly 60 cycles, in the receiver using full-wave rectification is 120 cycles, but as a broad generality these frequencies may be treated as if they were d.c., be-

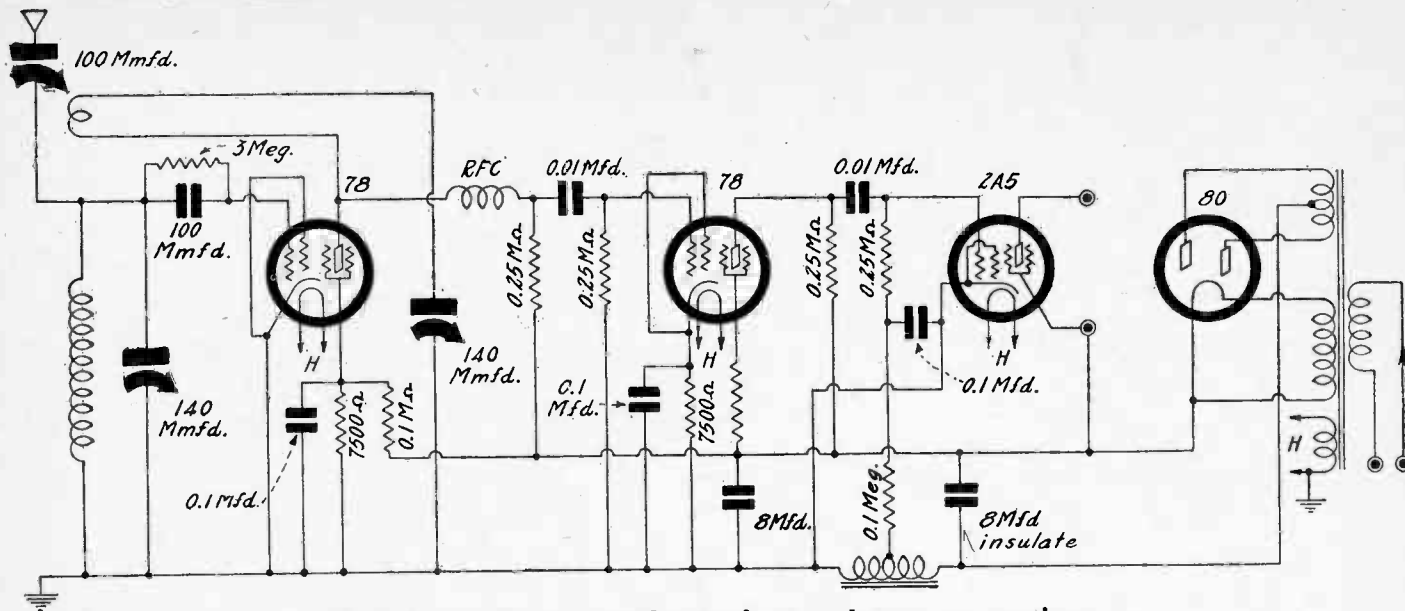

The circuit diagram of the 4-tube a-c short-wave receiver.

cause they are so low, and the impedances encountered therefore are not so different from the d-c resistance.

For instance, in the grid return of the four-tube a-c short-wave receiver diagrammed and illustrated herewith, the 0.25-meg resistor is returned through 0.1 meg. to a tap on the choke, which choke is in the negative leg. Thus the tube is given a negative bias equal to the drop in voltage due to current flow between tap and ground. Since ground is positive in respect to B minus, the tap, being toward B minus, is negative in respect to ground, and the voltage being around 20 volts, so is the negative bias. The condenser is 0.1 mfd., but in some instances the capacity will have to be higher.

In all instances the expediency of reversing the connections to the primary of the output transformer built into the speaker should be tried. Often the hum reduction is very considerable when the phase is shifted this way, for then electro-magnetic coupling is eliminated.

The same filter system, using a condenser and a resistor may be tried in the detector plate circuit, although once the reduction of hum has been made considerable in the grid circuit of the power tube it is hard to reduce it any more in the detector. Usually if a resistor of 0.1 meg. or thereabouts is used, the condenser from joint of the plate load resistor (0.25 meg) and the extra resistor of the filter, to ground, has to be very large indeed, values of 1 mfd. to 8 mfd. not being extraordinary for the purpose.

Then another advantageous method consists in reducing the B voltage for r-f and detector from maximum by interposing a resistor between the B plus lead from the rectifier filter and the return of the r-f and detector plates. In this instance that return is taken care of by the series plate resistor just mentioned, but if there are r-f stages (here there is none) all the r-f B current should be passed through the resistor, and the drop through the resistor should not be less than 50 volts. Then a capacity from the common B return of the r-f and detector circuits to ground may be 1.0 mfd. to 8 mfd. or more, and reduction in hum may be very considerable.

The screen circuit usually behaves in the opposite direction, because hum being an audio frequency, if a high-resistance load is put on the screen, say of the order of megohms, if the bypass capacity from screen to ground is made very large, the low audio frequencies will be given extra consideration, and as the hum frequencies are in this region, the hum may increase, though the fidelity of the system as a whole would be improved. Often the designer or constructor is faced with the necessity of modifying the audio-

amplifying characteristic so as not to bring out the hum too much. But the series plate resistor and series power-tube grid resistor, do not have this frequency-discriminating effect, and yet they are productive of results in the same desired direction.

Hum due to coupling between the detector and the power transformer is a rarity, in respect to electro-magnetic lines, because of the vast difference in frequency. More usually the coupling is direct, that is, due to the common path through some impedance like a resistor or an audio coil.

Also, audio transformers may couple magnetically to power transformers to

pick up hum, particularly when there are two transformer-coupled stages, and therefore also resistance coupling gets away from this danger.

### The "Static Field"

But besides the magnetic fields there are static fields. A sensitive detector will have a strong static field, so a shield around the tube is advisable, and the detector should not be too close to the rectifier tube or power transformer. Magnetic fields can modulate static fields. The static field is the electric field and refers to "standing electricity," as contrasted with moving electricity.

(Continued on next page)

## The Brute Force Filter Compared to Tuned Choke

IN nearly all B supplies the filter consists of "brute force" filter sections. They are all right, of course, but better filtering can be achieved with less apparatus. In practically all filters there is one main hum frequency to be suppressed; and when that is the case it is not reasonable to provide for complete suppression of all frequencies above a certain value if by a slight artifice better filtering can be obtained at the particular frequency with less equipment.

Suppose we have a filter consisting of series chokes and shunt condensers. That is a brute force filter. An example of such a filter might consist of one 8 mfd. condenser in shunt with the line, a 30-henry choke in series, and then another 8 mfd. condenser in shunt. This constitutes a single pi-section in which the series element is 30 henries and the shunt element is 16 mfd. This filter has a cut-off at 14.5 cycles, which is so low that the attenuation at the main hum frequency will be considerable whether that be 60 or 120 cycles.

### Higher Attenuation

Still the attenuation can be made much higher at the hum frequency by tuning the series inductance to the frequency. If it were tuned exactly to this frequency and if the coil had no resistance, the attenuation would be infinite at the hum frequency. With finite values of resistance the attenuation will still be high at the resonant frequency, and it will be higher the lower the resistance in the coil. Let us suppose that the effective value of the coil is 30 henries and that it is required to tune the circuit to the main hum frequency, 120 cycles. What should the value of the capacity be? According

to the frequency formula it should be 0.0585 mfd. This should include the self capacity of the coil.

The addition of the critical condenser to the series coil will increase the attenuation only at the main hum frequency to which the circuit is adjusted. At higher frequencies, and therefore at the harmonics of the hum frequency, the attenuation will be less than it would have been with a brute force filter. Since the higher harmonics may be audible in the receiver it is necessary to suppress them. This is best done by a section of brute force filter. The entire filter would then consist of one section of brute force filter and one section of tuned filter.

### Examples Cited

The attenuation characteristic of the brute force filter is well known. The attenuation begins at  $f_0$ , the cut-off, and then rises continuously as long as the frequency increases. Also well understood is the similar characteristic of a filter composed on one section of brute force and one section tuned filter. The condenser across one of the coils has been adjusted so that there is resonance in the series arm at 120 cycles. The attenuation does not increase quite as fast above the 120-cycle peak as the curve would indicate, but it does increase and the higher harmonics are suppressed.

Since the degree of suppression at the hum frequency is greater the lower the losses in the coil, and since the losses are likely to be lower the smaller the coil is, resonance should be obtained by using a large condenser and a small coil. This combination will decrease the attenuation on the harmonics, but the brute force section will suppress them sufficiently.

At left is a typical diode and automatic volume control, utilizing the 55, or any similar tube. Diode bias is used on the triode. At right is shown how a pentode can be used as a diode rectifier.

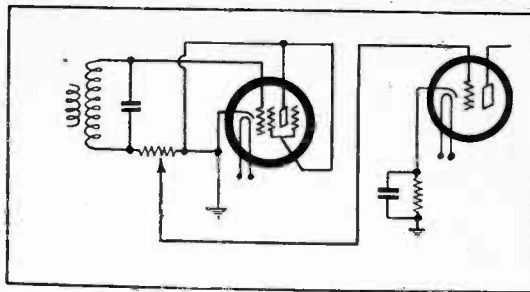
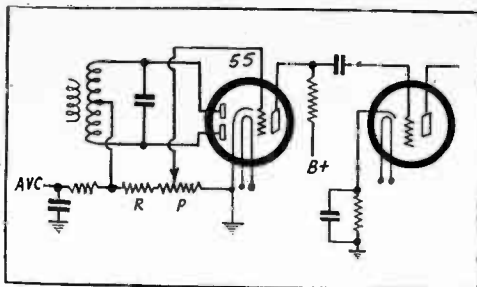

## Use of the Pentode As A Diode Rectifier Tube

The conventional way of using a 55 duplex diode triode in a full-wave rectifier-detector and automatic volume control is illustrated at left. The secondary of the coil is tapped at the center point and between this point and the cathode is connected the load resistance, which in this case consists of a high resistance potentiometer in series with a fixed resistance. Of course, the resistance R is not essential to the circuit, but is used occasionally.

The automatic volume control voltage is also taken from the load resistance, but a high resistance, usually 0.5 megohm, is connected between the grid returns and the center tap of the transformer and the negative end of the load resistance.

### Bias Varies

Since the grid of the triode part of the 55 is connected directly to the slider on the potentiometer, the triode is diode biased. The bias will vary according to the volume, yet it will never be insufficient unless the modulation is excessive. In that case good quality is impossible regardless of what bias or what detector is used.

The coupling between the 55 triode and

the next tube is done in the usual resistance-capacity manner. The grid leak, however, pertaining to the second tube has been omitted from the drawing. It should, of course, be connected between the grid and ground.

The right-hand drawing shows a way of utilizing a pentode as a diode rectifier. All the elements with the exception of the grid are connected to the cathode and the grid alone is the anode of the rectifier. The amplifier in this case is another tube, the grid of which is connected to the slider of the potentiometer that serves a load resistance for the certifier.

### Resistor Is Shunted

It will be observed that there is a condenser-shunted resistor in the cathode lead of the second tube and that the cathode of the rectifier is connected to ground, the same point as the negative end of the bias resistor for the second tube. The second grid is therefore biased by means of the fixed resistor. In addition to this it is diode biased. If this results in excessive bias it is easy to provide a stopping condenser and a grid leak for the second tube and thus make the bias fixed.

## 4-Tube Short-Wave A-C Set Without Hum

(Continued from preceding page)

From the foregoing it can be gleaned that hum can be eliminated to just as satisfactory extent in a self-contained short-wave receiver as in such a set intended for broadcast use. In fact, there are so many self-contained short-wave receivers on the market, and the hum is negligible in most of them, that it seems idle to argue the point. Experience proves that proper design will accomplish hum elimination though the power supply is in the receiver, which is no argument against the use of a separate power supply, either. Perhaps the result can be attained more economically or with less experimenting and general effort than by the self-contained method. But when the solution is made for the self-contained model it is made.

### High Screen Resistor

In the four-tube a-c receiver herewith such hum-reducing adjuncts were introduced as were found advisable. The layout of parts, as intimated, has something to do with the results. The filters do the rest. One of the methods used is to have a high resistance in the screen circuit of the first audio amplifier, without a condenser across it, or, if one is put across it, the capacity should not exceed 0.1 mfd. The power stage grid circuit filter is the other specialty.

How the circuit was built up by Prompt Radio Company is illustrated in the photograph, and the layout of parts is obvious. There is one plug-in coil for each band, the set of coils being of commercial manufacture, and the location of the coil socket being accessible to the open rear of a cabinet. Seen from the front, the panel would show the feedback or throttle condenser at left, the tuning condenser at right. Both these condensers are 0.00014 mfd. (140 mmfd.).

### Foreign Stations on Speaker

When the circuit is built it will be found to yield satisfactory speaker results, including the reception of foreign stations, and will provide adequate sensitivity and selectivity if the regeneration control is working properly. This proper performance of the key to success in the set depends to an extent on the setting of the series antenna condenser, hence this capacity also is made adjustable for each band. A postage-stamp type condenser at the rear would do.

The circuit has a regenerative detector (58), a first-stage audio amplifier or driver (58), a pentode power tube (2A5), and a rectifier (80). The B choke is the field coil of the speaker, total d-c resistance 1,800 ohms, of which the resistance between tap and grounded side is 300 ohms.

## Subscribers! Important!

Note subscription expiration date on wrapper containing your copy of RADIO WORLD. If nearing expiration date, please send in renewal so that you will not miss any copies. Subscription Dept., RADIO WORLD, 145 W. 45th St., New York City.

## Unique Use of the 55 With Optional A. V. C.

Here is a unique arrangement of the elements of a duplex-diode-triode tube. One of the diode rectifiers is used as detector, the other as an automatic volume control, and the triode is used as a diode-biased amplifier in a resistance-capacity setting. The circuit can be converted to a fixed-bias amplifier by connecting the resistor that is now between the grid and the left end of R instead between the grid and the lower end of R<sub>1</sub>. This resistor, R<sub>1</sub>, would then be the bias resistor.

The circuit is not complete, of course, but a load resistance is indicated in the plate

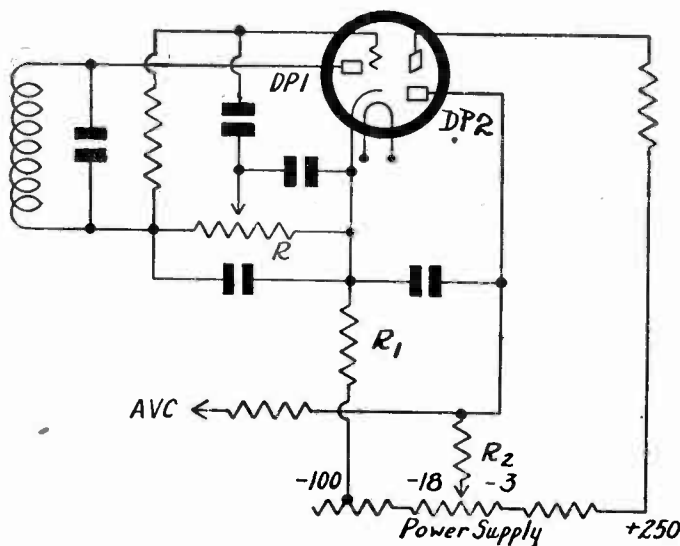

This illustrates a method of using a duplex diode triode as detector, automatic volume control, and resistance coupled audio amplifier.

circuit of the triode. The next amplifier is coupled to the pres-

ent amplifier by means of a condenser from the plate to the next

grid and a grid leak in the usual manner of loading such circuits.

# Diodes for T. R. F.

## Getting Around the Obstacle of Grounding

By Casper C. Workman

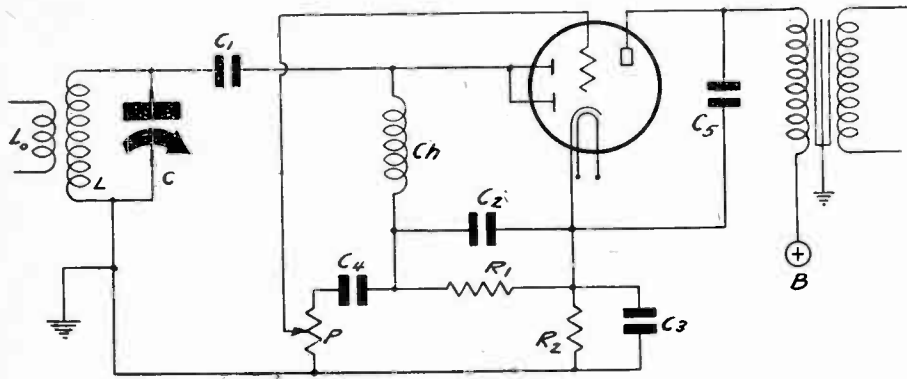

FIG. 1

This illustrates how radio-frequency tuned circuit can be connected to a diode detector, leaving the triode properly connected for amplification

however, for the only thing that militates against the possibility is that the signal is modulated over 100 per cent, and that does not occur any more.

SOMETIMES it is desirable to use diode detection in a radio-frequency circuit and to tune the circuit immediately preceding the rectifier. How can this be done advantageously? In Fig. 1 is a typical circuit. The two diode plates are tied together, in this particular case, and then the anode thus formed is connected through a condenser, C1, to the top of the resonant circuit. The other side of that circuit is grounded. A return to the cathode of the rectifier is made through a condenser C3. This traces the a-c circuit by which the radio-frequency signal is impressed on the tube. To provide a d-c circuit without shorting the a-c input, a choke, Ch, is connected between the anode and the load resistance, R1. Thus we get a d-c circuit around which the rectified current can flow. Condenser C2 simply by-passes some of the high-frequency currents which reach the load resistance.

It is desirable from the point of view of sensitivity that C1 be as large as possible. Still it cannot be made indefinitely large because it would by-pass the audio signal. Ch, also, should be large to prevent the radio-frequency signal from shorting through it, yet it is limited to a fairly low value because the audio signal must flow through it; and if the choke has a high inductance, the higher audio notes will suffer a depression.

The triode part of the rectifier tube has a fixed bias, the drop in resistor R2 for the grid return is connected to ground. C4 is the grid stopping condenser and P the grid leak, which also serves as manual volume control.

The following values of the various parts are suitable for both broadcast and short-wave detection:

- L0L, appropriate tuning coil.
- Ch, 10 to 85 millihenries.
- C, tuning condenser appropriate to the frequency band to be received C1, 0.00025 mfd.
- C2, 0.0001 mfd.
- C3, 25 mfd. electrolytic.
- C4, 0.01 mfd.
- C5, 0.0005 mfd.
- R1, 500,000 ohms.
- R2, 2,500 ohms.
- P, one megohm.

In Fig. 1 a transformer followed the triode, which was permissible because the bias on the tube was fixed and sufficient. In Fig. 2 is a similar detector circuit but in this the bias is of the diode type and a resistance-capacity coupler follows the triode. The load resistor is a high-resistance potentiometer which is used for manual volume control as well. In Fig. 2 provision is made for automatic volume control in addition to the manual. Resistance, R2, which may have a value of 500,000 ohms, is connected between the negative end of the load resistance and the grid returns of the controlled tubes. A condenser, C4, of 0.25 mfd., by-passes the common grid return to minimize coupling.

Diode bias is permissible in this case because there is a high resistance, R1, in the plate circuit of the triode which limits the current to small values for all potentials the grid is likely to assume. A suitable value of R1 is 250,000 ohms, and C3, the by-pass condenser, may be omitted.

Suitable tubes for these circuits are the 55 in the 2.5-volt series, the 85 in the 6.3-volt series, the 2A6 high mu triode in the 2.5 volt series, and the 75 high mu triode in the 6.3-volt series. The high mu tubes, however, are not particularly suitable when diode bias is used on the control grid. They are too easily overloaded and many receiver operators will not take the trouble to manipulate the manual volume control so that this overloading will not occur. It is always possible to do so,

### Recent Changes in Broadcasting List

- WMAQ—Chicago, Ill. C.P. power 50 kw.
- WMBH—Joplin, Mo. Licensee, Joplin Broadcasting Company.
- WNBH—New Bedford, Mass. Licensee, E. Anthony and Sons, Inc.
- WOR—Newark, N.J. C.P. T-Carteret.
- WQDM—St. Albans, Vt. Licensee, E. J. Regan and F. Arthur Bostwick, d/b as Regan and Bostwick.
- WSAR—Fall River, Mass. T-Somerset.
- WTIC—Hartford, Conn. S.A. Exp. operate simultaneously with KRLD on 1040 kc, U, quota units 2.0.

### Corporate Activities

Radio-Keith-Orpheum Corp.—The reorganization petition filed by the corporation was approved by Judge Cox, who continued the Irving Trust Company in possession and operation. For several months this trust company has been acting as receiver in equity.

Zenith Radio Corporation—Net profit of \$50,398 after depreciation, taxes and other charges, for the year ended April 30, 1934. This equals 10 cents a share on 492,464 no par capital shares. In the preceding fiscal year there was a net loss of \$578,110. On April 30, 1934, the current assets, including \$367,445 cash, amounted to a total of \$1,641,070, and current liabilities, \$688,467; as compared with cash and government securities, \$393,810; current assets, \$803,425, and current liabilities, \$326,009 on April 30, 1933.

### BANKRUPTCY SCHEDULE

Paramount Radio Mfg. Co., Inc., of 34 East 12th St., New York City—Assets, \$8,104, liabilities, \$5,696.

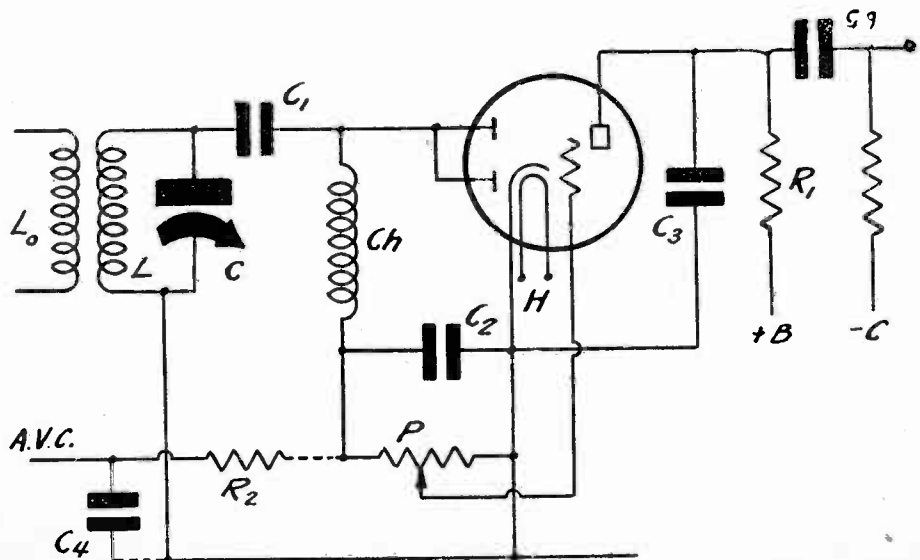
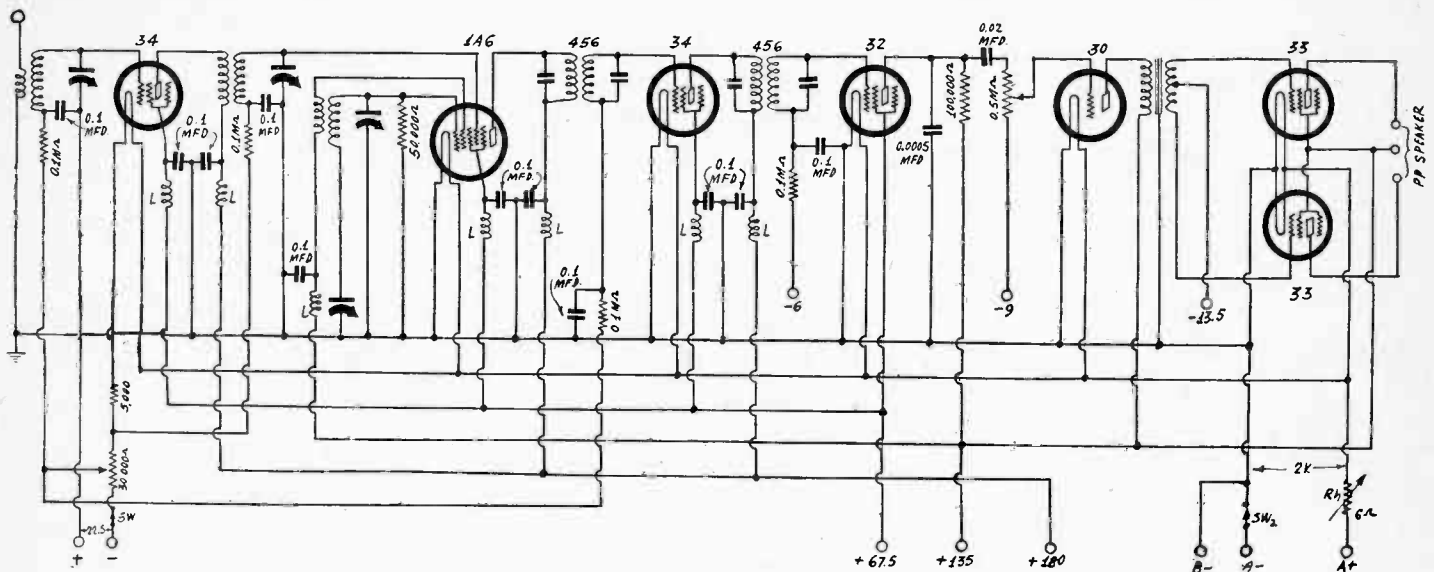

FIG. 2

A similar circuit to that in Fig. 1 but arranged for automatic volume control, for diode bias on the triode, and resistance coupled output.

# High Sensitivity and Selectivity in a Battery-Operated Super

By Roscoe J. Weldon



The circuit of a seven-tube battery-operated superheterodyne incorporating the latest tubes, together with push-pull output.

**Q**UITE often we receive requests for battery-operated superheterodynes. Why should any one want such a receiver at this time, when a-c operated circuits are more economical, usually more powerful, quite often more sensitive and more selective, and in general superior? There are many reasons.

First, in many places in this country—in every country—there is no electrical power available, and the only way that radio reception can be enjoyed is through the medium of a battery-operated circuit. Some of these places that are lacking in electric power service are right in the large cities.

Second, most of the places where battery-operated receivers must be employed are remote from broadcast stations, and the only practical circuit is a superheterodyne, for that alone has the requisite selectivity and sensitivity.

Third, in most instances there is less distracting noise accompanying the signal brought in by a battery-operated receiver than by an a-c operated receiver.

Fourth, there are many portable uses for a receiver, for example, on boats, trains, autos, airplanes, packs.

While a-c operated receivers can be used in some of these applications, the battery-operated circuit is often preferred; especially is this the case on small boats and pack trains.

## The Kind of Receiver

As we have mentioned, the choice is nearly always a superheterodyne, one that is sensitive enough to bring signals to the remotest nooks. A receiver that surely is sensitive enough for any portable application is illustrated herewith. It has a stage of radio-frequency amplification, using a 34 super-control tube. Then follows a 1A6 as frequency converter, serving both as detector and oscillator. After this tube is another 34 super-control tube acting as intermediate-frequency amplifier. There follows a 32 grid bias detector, a 30 audio amplifier, and finally a stage of 33 push-pull. Surely, this circuit has enough gain in all departments and it also has enough output.

The circuit is provided with three means for controlling the volume. First there is a potentiometer by which the grid bias on the two super-control tubes can be varied. Then there is another potentiometer for controlling the audio input to the 30 tube. Finally, there is a rheostat in the filament supply circuit by means of which the filament current, and hence the gain, can be controlled.

One of the most important features of the circuit is the thorough filtering that is used in every position where feedback might occur. There is a radio frequency choke in every screen and plate lead, and for each choke there is a by-pass condenser of 0.1 mfd. In each grid lead is a filter resistor, and this, too, is accompanied by a 0.1 mfd. condenser to make the filtering more thorough. In a circuit as well filtered as this one there should be practically no feedback, either to cause oscillation or regeneration or to cause degeneration. There may, of course, be some feedback through the air where coils and leads are not thoroughly shielded from each other; but such coupling should be negligibly small if ordinary precautions have been taken against it.

## Intermediate Frequency

It will be noticed that the intermediate-frequency coils are marked 456 kc. In recent superheterodyne design this is the most popular intermediate. It is high enough to make certain that image interference will be suppressed in the radio-frequency tuner, it is low enough to make it practical when the oscillator is padded, and it is odd so that there will be a minimum of squealing.

The oscillator circuit should be padded for greatest convenience in tuning, and it is padded in this case. The series condenser is put between the tuning coil and ground, and thus it can be adjusted accurately without any trouble from body capacity. It will be observed that this condenser also serves as the grid stopping condenser.

The value of the oscillator inductance for the 456 kc intermediate we can obtain from the curves on page 6, July 7, 1934,

issue of Radio World. It should be 138 microhenries if the inductance in the radio-frequency circuit is 245 microhenries; and this value is right when the maximum capacity of the tuning condenser is 350 mmfd. The value of the series padding condenser is given by the C<sub>s</sub>-curve on the same graph as exactly 300 mmfd. The C<sub>m</sub>-curve shows that the minimum value of the tuning condenser should be nearly 9 mmfd, greater than the minimum in the radio-frequency circuits. This excess is easily obtained by making an adjustment on the trimmer on the oscillator condenser. Condensers of the compression type which will cover the 300 mmfd. value are obtainable.

Note that the padding values just given apply only when the inductance in the radio-frequency is 245 microhenries, when the maximum value of the tuning condenser in any one of the circuits, including the oscillator, is 350 mmfd. The three frequencies at which the tracking will be perfect are 600, 1,000 and 1,450 kc. The greatest deviation from perfect tracking, within the broadcast band, will be about 5,000 cycles, assuming that all the inductances and condensers have the specified values and that the intermediate is 456 kc. If the adjustment is not perfect, the deviation may be larger; but if reasonable care has been taken in tracking, the deviation should be small and negligible.

## The Filament Supply

Five of the tubes in the circuit require 0.06 ampere each for the filament and the other two require 0.26 ampere each. Thus the total current requirement is 0.82 ampere. This is best supplied by a small storage battery of a single cell. If, however, dry cells must be used, they should be No. 6, and they should be two in series and four in parallel. That is, there should be eight cells. Of course, for brief periods, the set will work on two cells connected in series.

A medium size B battery should be used for supplying the plate and screen currents, and a small battery to supply the bias.

# Radio University

## Best Type of Coil

WHAT IS the best type of coil for short waves? Has the form on which the coil is wound any particular importance?—K. H.

The solenoid is considered the best coil. This consists of winding on a hollow insulation tubing of circular cross-section. A slight modification of this is the polygonal type winding occasioned by the ribbing of the form, so that only a small part of the wire actually touches the form. The material of the form is important, as it should not be affected by moisture, heat and cold, otherwise the effective diameter would change, and so would the inductance. Moisture is particularly a nuisance. Coils that are practically impervious to moisture are called non-hygroscopic. Also, the form should be free of injurious ingredients, especially iron and the like. Variations in the quantity of these extraneous substances make production of the same inductance from the same number of equally-spaced turns impractical. Specially treated material which may be moulded is popular in good coils, the iron having been removed and some mica dust included in a phenolic compound. High-grade porcelain also is popular. Some ignitable materials, capable of moulding, however, make excellent forms, showing no heat losses even at very high frequencies. Tube bases do not make good coil forms.

\* \* \*

## Two-Tube Set

PLEASE SHOW the simplest two-tube short-wave set for battery operation, using the 30 tubes.—O. H.

The circuit herewith uses a regenerative detector and a stage of transformer-coupled audio. The regeneration control is the series plate rheostat, which should have a high resistance, 100,000 ohms maximum, or more. The rheostat in the filament leg is set once, so that the tubes will read 2 volts exactly across the filaments. However, as the A battery becomes partly used up, even from age, and as the tubes change their resistance a bit, the rheostat would be adjusted from time to time, the object being to keep on maintaining the 2 volts. The B voltage

for the detector may be 45 volts and for the amplifier 90 volts. The negative bias of 1 volt for the amplifier, due to the difference between negative filament and grid return, or the potential drop in the rheostat, is not sufficient for economical operation of the amplifier at 90 volts, and a 4.5-volt C battery may be connected here, between F and ground, with minus to F and plus to ground, in the grid return circuit of the amplifier. The series antenna condenser, if fixed, may be very small, around 10 to 20 mmfd., or, if variable, may be 50 mmfd. maximum. The detector plate bypass condenser may be 0.0001 to 0.00025 mfd. The transformer ratio for audio coupling is not vastly important, but ratios of 3.5 to 1 are popular. Differently-colored leads may be used for cabling to the batteries, to minimize risk of misconnections. The output is connected to a phone-tip-jack twin assembly, which is a moulded device with the two inset tip jacks. The values of the leak and condenser should be low if the frequencies are to be high, e.g., 50,000 ohms and 0.0001 mfd. would be all right for frequencies up to 20 mcg (down to 15 meters). A circuit like this is just the kind for a beginner in radio. There are few connections, the circuit works well, and often great distances are covered. Commercial plug-in coils and 0.00014 mfd. (140 mmfd.) tuning condenser may be used. This combination of inductance and capacity is practically standard.

\* \* \*

## Results Become Practically Nil

DURING THE PAST several weeks I have not been getting good results out of my short-wave set, while during the best part of the Winter I got excellent results. Can the trouble be due to meteorological conditions, or must it be due to the receiver, hence should I have the receiver serviced?—G. V. O'C.

Abrupt and vast changes in reception conditions take place wherever great distances are to be traversed, and apply to long waves as well as to short waves, though for different reasons. Certainly it is reasonable to suppose that the transmission conditions are at fault. There are times when hardly anything save a

few locals can be received on the short-wave bands from beginning to end. Nevertheless, it is possible something has gone wrong in the receiver, and it would be highly advisable to have a service man check up for you, especially since if he finds nothing wrong you can feel that meteorological conditions are the real cause.

\* \* \*

## Resonance Explained

HOW CAN ONE get a good grasp of what takes place when one tunes a receiver? I know practically nothing about radio, all I do is turn the dials and other controls to bring in stations and adjust volume, but I often wonder if it is possible to inform a layman why it is that a station is tuned in? What is the principal thing that makes a set work?—R. D.

Each station transmits a carrier, which may be regarded as an electric impulse of alternating-current or voltage of a particular frequency. This carrier bears no intelligence. To endow it with the "message" a process known as modulation is required. This changes the frequency of the carrier a bit, or leaves the frequency practically constant and changes the strength or amplitude of the carrier. Thus a speech or a musical rendition may be mixed with the carrier, to change that carrier in a manner exactly duplicating the original audible frequencies created by the speaker or musician. Since the change in frequency, if any, due to this imposition of an audio characteristic on the super-audible carrier, is slight indeed, no account need be paid to it in considering tuning. In the receiver the circuits must be so adjusted that the desired wave will be brought in. This is done in practice by using a fixed inductance for any band of radio-frequency tuning, and changing the capacity. The tuning condensers therefore are variable. They have the electric property of being able to store energy. They keep it for a period related to the quantity of electric capaciousness they possess. Thus the condenser is charged and discharges. The coil has lethargy, so to speak, and resists changes. In physics this is comparable to inertia. When antenna voltage is put into a coil, or communicated in amplified state in subsequent circuits of an amplifying-tube chain, the coil charges the condenser. When the rate of charge of the condenser by the coil is equal to the rate of discharge of the condenser into the coil, hence the two estab-

(Continued on next page)

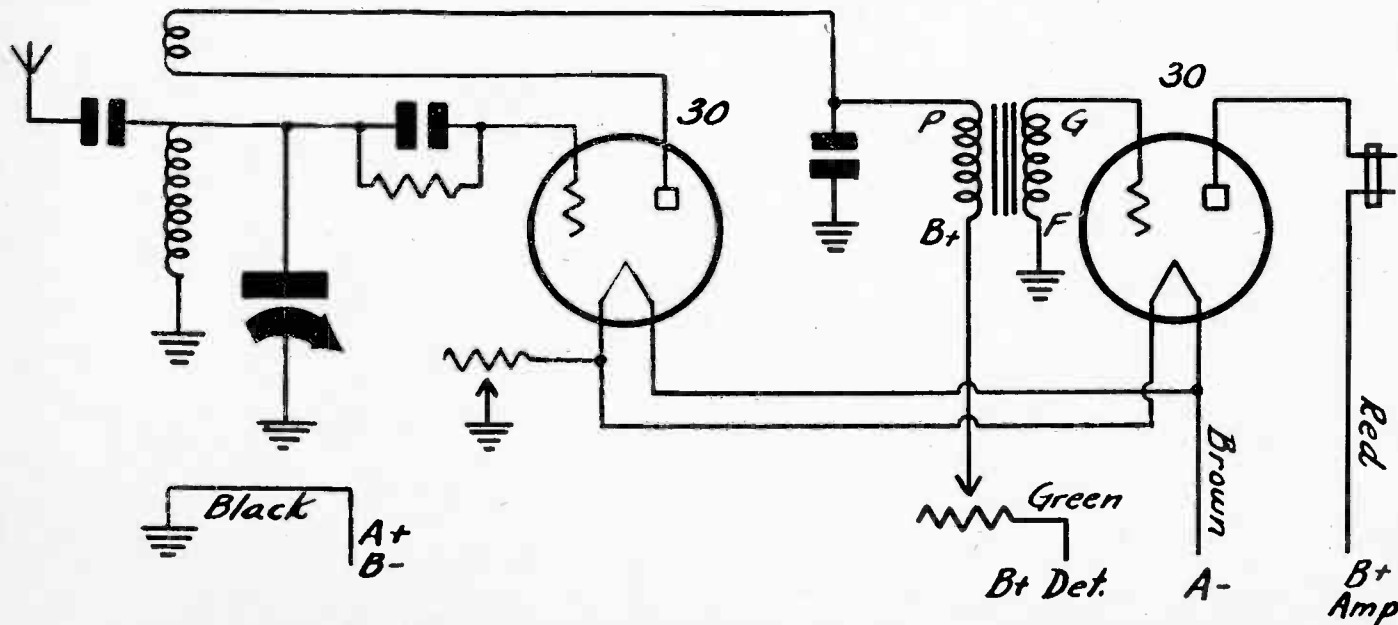

A typical circuit for the beginner, consisting of a regenerative detector and a stage of audio-frequency amplification, for earphone use.

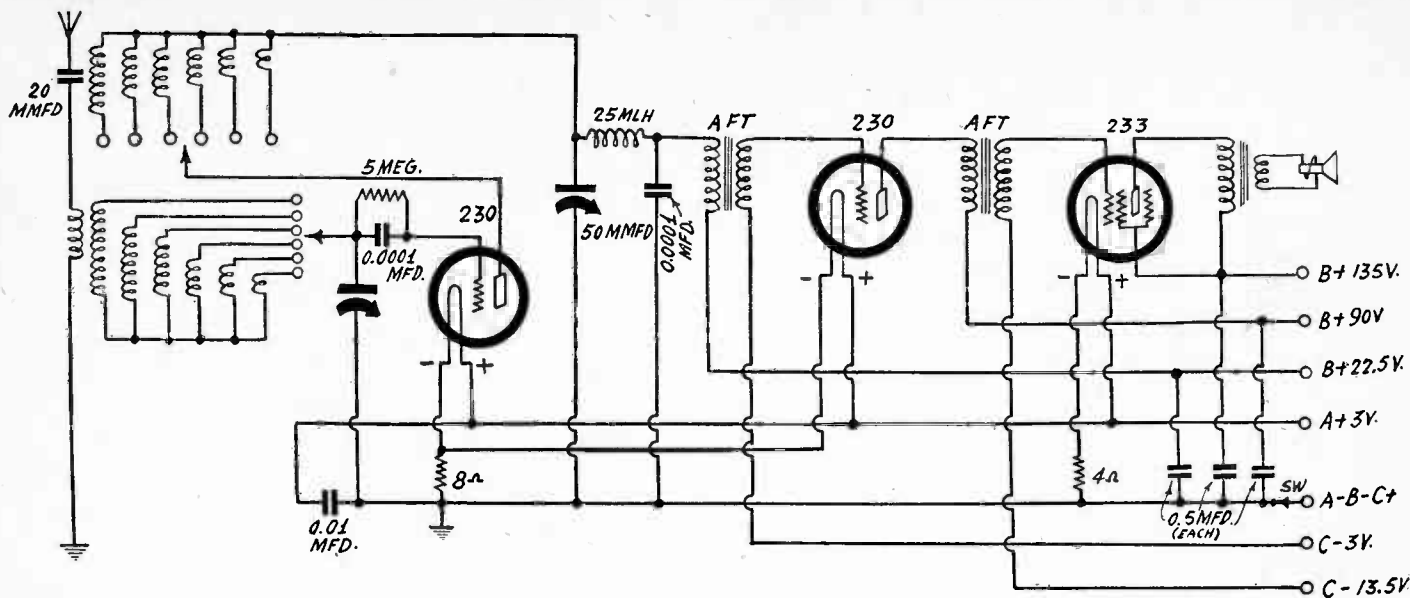

**A two-deck switch method of changing coils. It would be better to use a three-deck switch, so that the ticklers would be totally disconnected from conductive contact with the operating circuit, to minimize the risk of stray pickup of energy.**

(Continued from preceding page)

lish equality, a condition exists whereby the opposition offered by the coil-condenser system to the flow of alternating current is zero at a particular frequency. This is called the frequency of resonance, or simply resonance. For any combination of condenser capacity and coil inductance there can be only one resonant frequency. Therefore when you tune in your set you adjust a parallel capacity across a coil of such a value as to offer to the desired frequency the path of least resistance. As for the other part of the question, the principal thing that makes a set work may be said to be heat, as heat alone causes electrons to be emitted from those elements of vacuum tubes known as cathodes, and the whole operation depends on the flow and control of these electrons.

**Feeding Through the Line**

WHAT IS THE CAUSE of the condition of a signal generator, or test oscillator, feeding through the line? Is it permissible to use one of these line-feeding devices to set up interference in the receiver of a neighbor who plays his set loudly until 1 a. m., when others are trying to sleep?—T. G. F.

The so-called feeding through the line is due to the line cable which supplies power to the signal generator, acting as a transmitting antenna, and also to a small extent to stray radiation from the parts of the oscillator itself. This can be confirmed by letting the carrier get into a set to which antenna is connected, then disconnect the antenna from the set. The feed through the set will stop, because the receiving antenna has been removed. So instead of feeding through the line in a strict sense, the energy is radiated in the usual manner. It is practical to introduce interference in a neighbor's set in the manner you describe, but it is also unlawful to do so.

**Extra Switch Deck Advisable**

IS IT ALL RIGHT to use a two-deck switch for a regenerative short-wave circuit? Since the tickler is connected, one side to plate, other side also to a "hot" potential, at least not grounded, I was wondering if the two-deck system, which leaves one side of the tickler permanently connected for each band, would pass muster?—R. F.

The method you mention has been worked successfully, and is shown in the diagram, but it is not the better way.

Some dead spots may be the result, due to current flowing in coils that are not intended to be in use, and which coils may act as trap circuits. It has been found much more advisable to use the three-deck switch method. The series antenna condenser, if fixed, should be of small capacity.

**Pure Resistance**

Is a pure resistance a fact or a fiction? Where is it met, if it exists?—C. L.

A pure resistance does not exist in practice, for useful values of resistance. When measurements are to be made, for instance, requiring a condition equivalent to the presence of pure resistance (that is, resistance without inductance and capacity), the inductive problem is compromised by having each resistor thus used possess a known and fixed inductance, all inductance values equal. The capacity can be kept low enough to be neglected for nearly all work. This compensatory method is used in some commercial measuring devices whereby the residual inductance is said to be constant for all values of resistance. Resistors of this type also are essential in bridges for the measurement of small inductances that have a low ratio of reactance to a-c resistance at the measuring frequency.

**F**RANK BUCK is carrying on over WJZ, at 7:45 p. m., during the absence of Amos n' Andy, while the famous blackface entertainers are on a vacation. Mr. Buck is widely known as a hunter and adventurer; his sobriquet of "Bring 'Em Back Alive" was gained because of his occupation, that of wild-animal procurer for zoos and circuses; instead of shooting wild game, he risks his life at the infinitely more hazardous task of capturing them and bring them back to civilization alive. His adventures prove to be of hair-raising interest. He has signed a long contract with the Pepsodent Company, and upon the return of Amos n' Andy, will continue to be heard over the NBC facilities at a period to be assigned later. . . . This is the first vacation to be taken by Amos n' Andy for eight years. They are to go to England and other European countries and will be gone for two months. . . . And speaking of Europe, Jack Arthur left these shores on the Italian liner S.S. Conte de Savoie, for Monte Carlo, where he will entertain at a fashionable club, returning in the Fall to resume his broadcasting from WOR.

The Soconyland Sketches, now in their

**Station Sparks**

*By Alice Remsen*

seventh year of broadcasting over the NBC networks, are being heard on a different day and time, each Tuesday, at 9:30 p. m. over WJAZ and network. . . . There is a new lyrical Lochinvar, who came out of the West to conquer the Eastern air-waves. His name is Barry McKinley, and he made his nation-wide debut on July 16th, from WJAZ, at 3:00 p. m. in the interests of Camay Soap. Ray Sinatra and his orchestra accompanies this young baritone. The program features soft romantic melodies, and is titled "When Dreams Come True"; a three-a-week series, Monday, Wednesday and Thursday, 3:00 p. m.

Phil Baker, who, twenty years ago, started his theatrical career as secretary to Carl Laemmle, has gone to Hollywood to co-star for Laemmle in the forthcoming musical revue, "The Gift of Gab." His half-hour radio program will be

heard as usual each Friday at 9:30 p. m. over WJAZ and network, emanating from the NBC studios in Hollywood. . . . Richard Himber, the red-headed dance maestro of the Ritz-Carlton Hotel and the Studebaker program, has many accomplishments; he can play violin, vibraphone and celeste; is also an expert slight-of-hand artist and a fine eccentric dancer.

Dr. Walter B. Pitkin, author, traveler, former newspaper man and psychologist, has inaugurated a new weekly series over CBS; each Thursday, at 8:15 p. m. he will comment on current topics. Dr. Pitkin you will probably remember as the author of that best-seller, "Life Begins at Forty." . . . Ferde Grofe, distinguished composer, arranger and orchestra leader, is now directing his own group of musicians in a series of broadcasts over WA BC and network, from the city-owned Claremont Inn, New York. He is also heard each Saturday at 12 midnight over the same network. . . . The Blue Monday Jamboree, one of the pioneer variety shows in radio and a feature of the CBS-Don Lee network for eight years, is now available to Eastern listeners over a nation-wide network, each Monday, at twelve midnight.